

Collectieve RVS muurwasgoot voor 5 gebruikers
voorzien van rugwand, inclusief voorgemonteerde
leiding en KW kranen

3000 mm x 490 mm x 430 mm

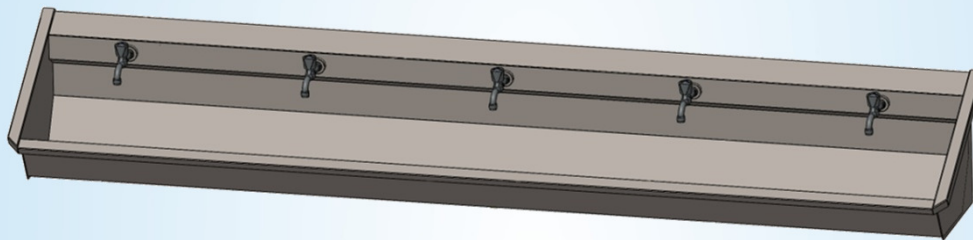

1.0-5-M2

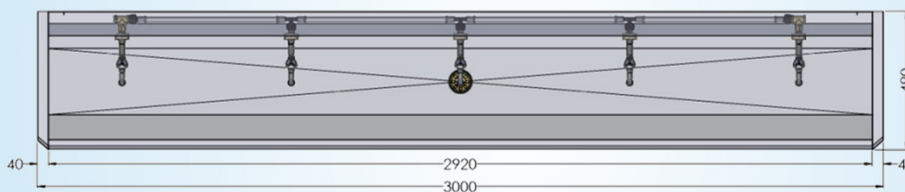
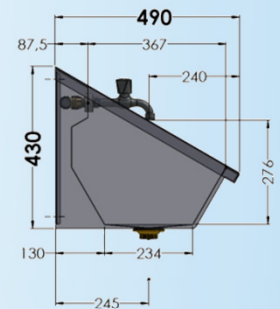
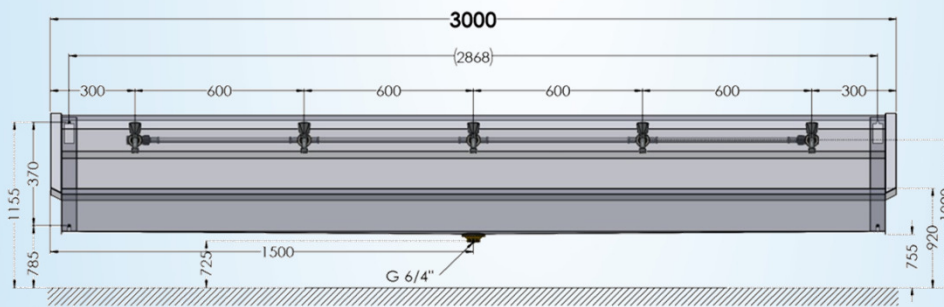

Logistieke gegevens :

gewicht
1 colli

netto: 30,772 kg

bruto: 35,772 kg

Sanilav®

Technische Fiche

Montage-instructies – Instructions de montage Mounting Instructions – Montage Anleitung

<p>A Bevestigingsgaten - Trous de fixation Fixation – Befestigung</p>	<p>B Na te meten – A mesurer To measure - Nachmessen</p>



VASTZETTEN / SECURE / ASSURER / SICHERN

Aansluitingschema – Instructions de raccordement Water connection Instructions – Wasseranschluss Anleitung

D : ZONE WATERAANSLUITING / ZONE RACCORDEMENT D'EAU / WATER CONNECTION ZONE / WASSERANSCHLUSSZONE

Intersan adviseert om een filter te monteren vóór de wateraansluiting (C) van elke wasgoot .
Intersan conseille à monter un filtre avant le raccordement d'eau (C) de chaque lavabo rigole .
Intersan advises to install a filter before the water connection (C) of every wash trough .
Intersan empfiehlt einen Filter zu installieren vor jedem Wasseranschluss (C) jeder Waschrinnen .

