

# AXOR<sup>®</sup>

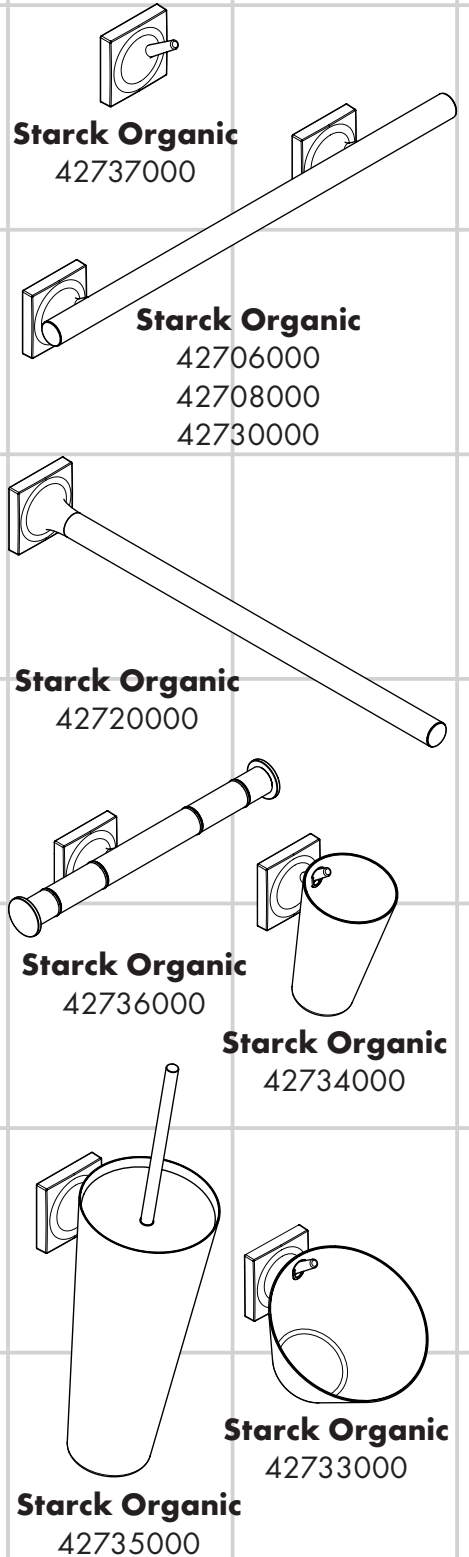



**hansgrohe**

<b>DE</b>	Gebrauchsanleitung / Montageanleitung	<b>2</b>
<b>FR</b>	Mode d'emploi / Instructions de montage	<b>2</b>
<b>EN</b>	Instructions for use / assembly instructions	<b>3</b>
<b>IT</b>	Istruzioni per l'uso / Istruzioni per Installazione	<b>3</b>
<b>ES</b>	Modo de empleo / Instrucciones de montaje	<b>4</b>
<b>NL</b>	Gebruiksaanwijzing / Handleiding	<b>4</b>
<b>DK</b>	Brugsanvisning / Monteringsvejledning	<b>5</b>
<b>PT</b>	Instruções para uso / Manual de Instalação	<b>5</b>
<b>PL</b>	Instrukcja obsługi / Instrukcja montażu	<b>6</b>
<b>CS</b>	Návod k použití / Montážní návod	<b>6</b>
<b>SK</b>	Návod na použitie / Montážny návod	<b>7</b>
<b>ZH</b>	用户手册 / 组装说明	<b>7</b>
<b>RU</b>	Руководство пользователя / Инструкция по монтажу	<b>8</b>
<b>HU</b>	Használati útmutató / Szerelési útmutató	<b>8</b>
<b>FI</b>	Käyttöohje / Asennusohje	<b>9</b>
<b>SV</b>	Bruksanvisning / Monteringsanvisning	<b>9</b>
<b>LT</b>	Vartotojo instrukcija / Montavimo instrukcijos	<b>10</b>
<b>HR</b>	Upute za uporabu / Uputstva za instalaciju	<b>10</b>
<b>TR</b>	Kullanım kılavuzu / Montaj kılavuzu	<b>11</b>
<b>RO</b>	Manual de utilizare / Instrucțiuni de montare	<b>11</b>
<b>EL</b>	Οδηγίες χρήσης / Οδηγία συναρμολόγησης	<b>12</b>
<b>SL</b>	Navodilo za uporabo / Navodila za montažo	<b>12</b>
<b>ET</b>	Kasutusjuhend / Paigaldusjuhend	<b>13</b>
<b>LV</b>	Lietošanas pamācība / Montāžas instrukcija	<b>13</b>
<b>SR</b>	Uputstvo za upotrebu / Uputstvo za montažu	<b>14</b>
<b>NO</b>	Bruksanvisning / Montasjeveiledning	<b>14</b>
<b>BG</b>	Инструкция за употреба / Ръководство за монтаж	<b>15</b>
<b>SQ</b>	Udhëzuesi i përdorimit / Udhëzime rreth montimit	<b>15</b>
<b>AR</b>	دليل الاستخدام / تعليمات التجميع	<b>16</b>





## Indicaciones de seguridad

-  Durante el montaje deben utilizarse guantes para evitar heridas por aplastamiento o corte.
-  Uso proyectado de la manilla 42730000: La manilla no es un producto médico, no es adecuado para personas con movilidad restringida sino destinada únicamente al ámbito privado.
-  Solo debe utilizarse exclusivamente la manilla para sujetarse, los demás productos no son adecuados para este uso.
-  Debe comprobarse en intervalos periódicos (anualmente) que los productos montados estén bien fijados y asentados.

## Indicaciones para el montaje

- En el momento del montaje del producto por parte de personal especializado y cualificado se deberá prestar una atención especial a que la superficie de fijación en toda el área de la fijación sea plana (sin juntas que sobresalen ni azulejos desplazados), que la estructura de la pared sea adecuada para un montaje del producto y que, ante todo, no presente puntos débiles. Los tornillos y tacos adjuntos son sólo apropiados para hormigón. En el caso de otras estructuras murales se deberán considerar las indicaciones del fabricante de tacos.
- Antes del montaje se debe examinarse el producto contra daños de transporte. Después de la instalación se reconoce ningún daño de transporte o de superficie.

## Descripción de símbolos



No utilizar silicona que contiene ácido acético!

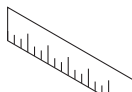

**Dimensiones** (ver página 21)







**Repuestos** (ver página 23)



**Limpiar**

ver el folleto adjunto.

## Veiligheidsinstructies

-  Bij de montage moeten ter voorkoming van kniel- en snijwonden handschoenen worden gedragen.
-  Reglementair gebruik van de handgreep 42730000: de handgreep is geen medisch product, hij is niet geschikt voor personen met een lichamelijke handicap en alleen bestemd voor privaat gebruik.
-  Alleen de handgreep mag gebruikt worden om zich vast te houden, de overige producten zijn voor dat gebruikdoeleinde niet geschikt.
-  De reglementaire bevestiging en de vaste zitting van de gemonteerde producten moet regelmatig (jaarlijks) gecontroleerd worden.

## Montage-instructies

- Bij de montage van het produkt door een vakkundige installateur moet men erop letten dat het bevestigingsoppervlak op één oppervlak zit (dus geen opliggende voegen of verspringende tegels), de wand geschikt is voor montage van produkten en zeker geen zwakke plekken bevat. De bijgevoegde schroeven en duvels zijn alleen geschikt voor beton. Bei andere wandsoorten dient u te letten op de voorschriften van de fabrikant van de schroeven en duvels.
- Vóór de montage moet het product gecontroleerd worden op transportschade. Na de inbouw wordt geen transport- of oppervlakteschade meer aanvaard.

## Symboolbeschrijving



Gebruik geen zuurhoudende silicone!

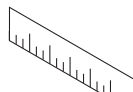

**Maten** (zie blz. 21)



**Service onderdelen** (zie blz. 23)

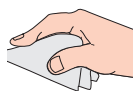

**Reinigen**

zie bijgevoegde brochure.

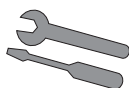

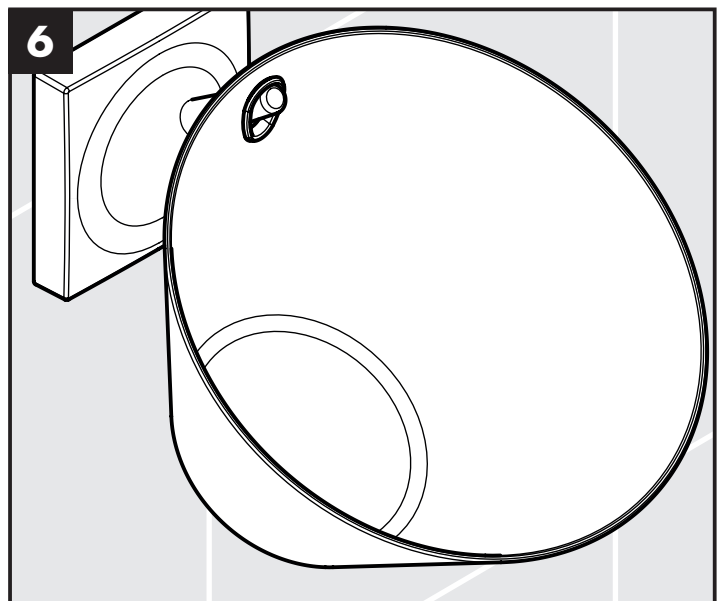
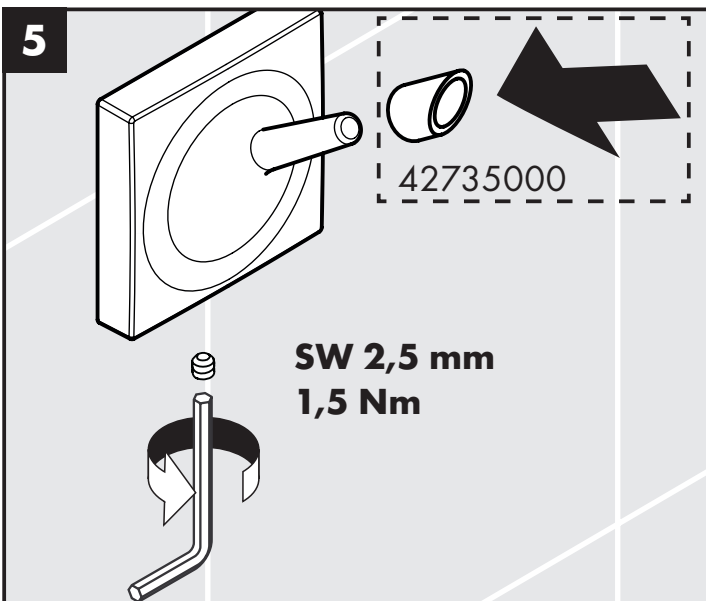
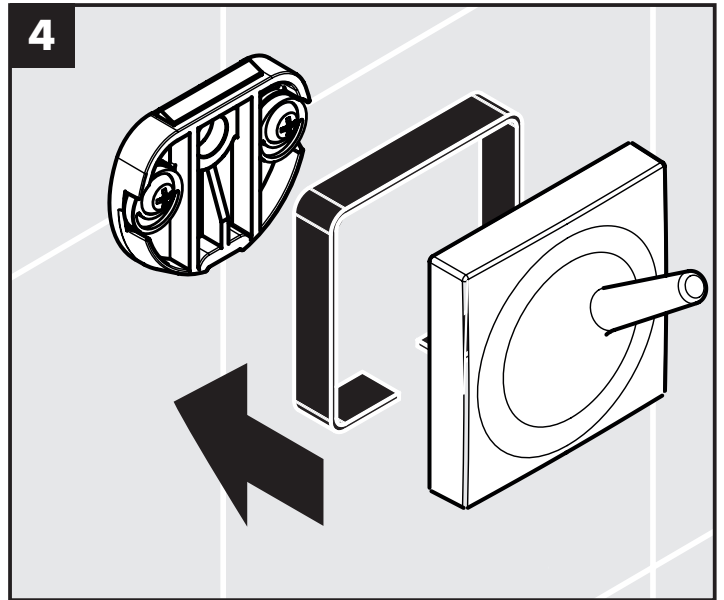
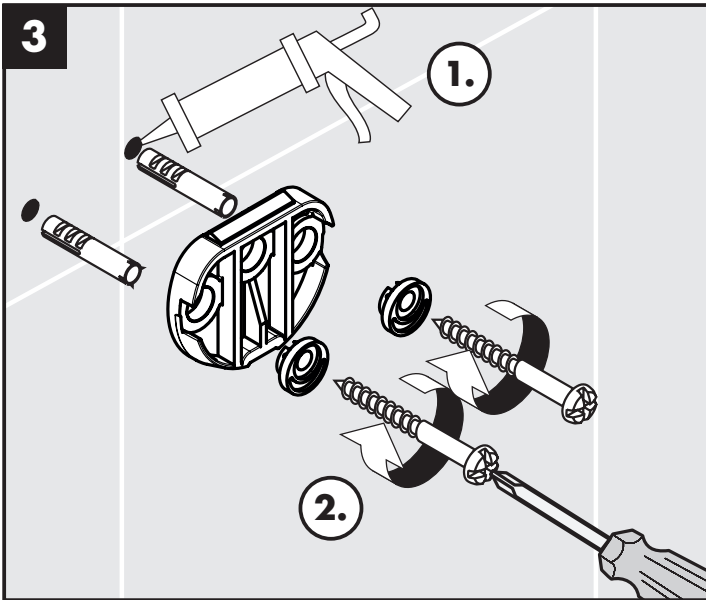
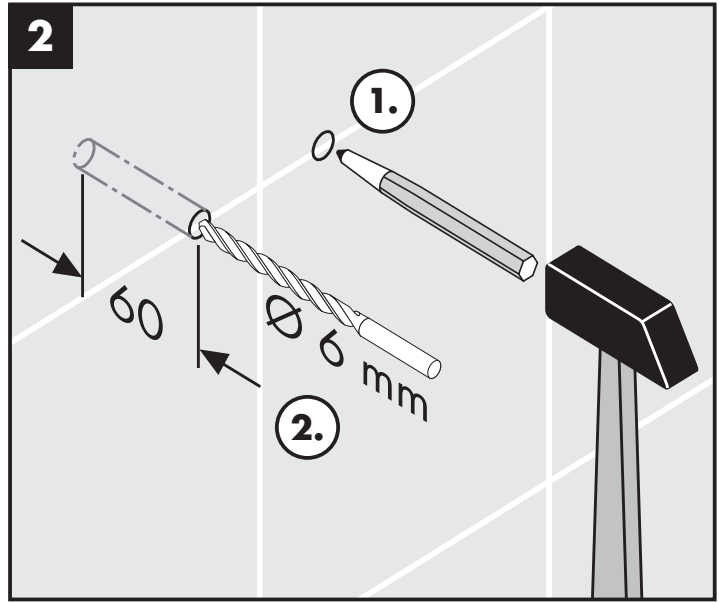
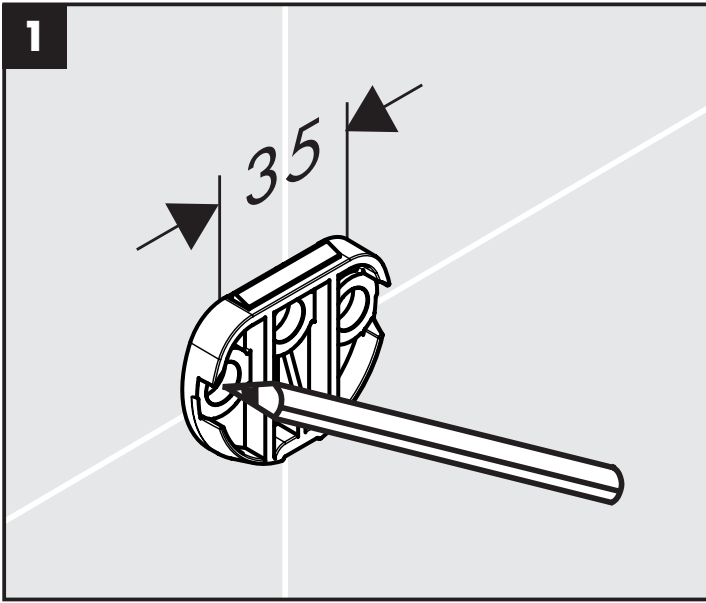
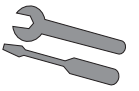

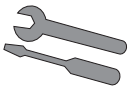

# Starck Organic 42736000

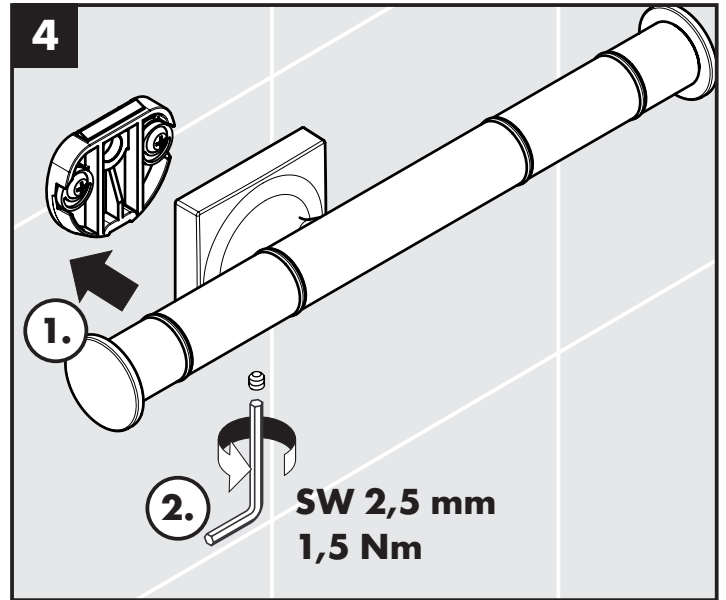
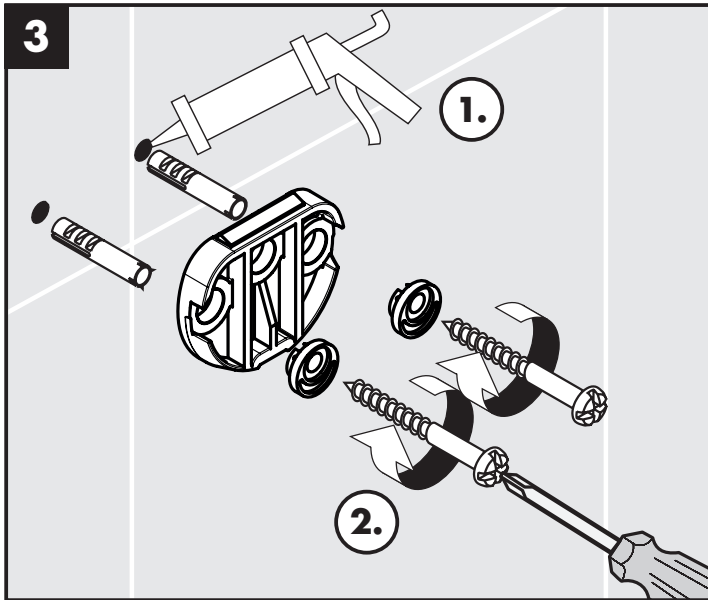
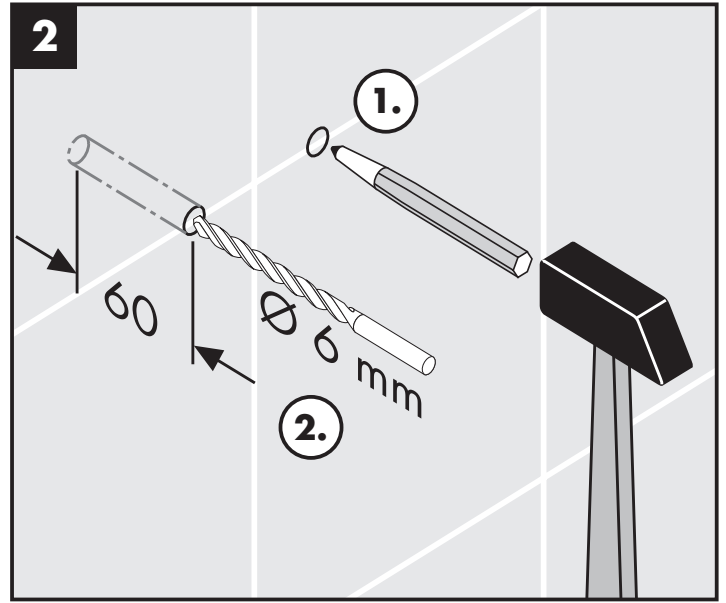
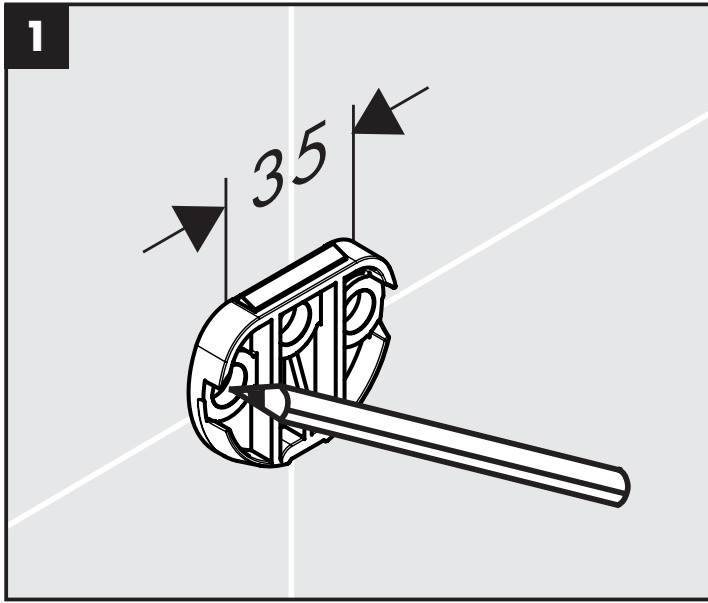

# Starck Organic 42706000 / 42708000

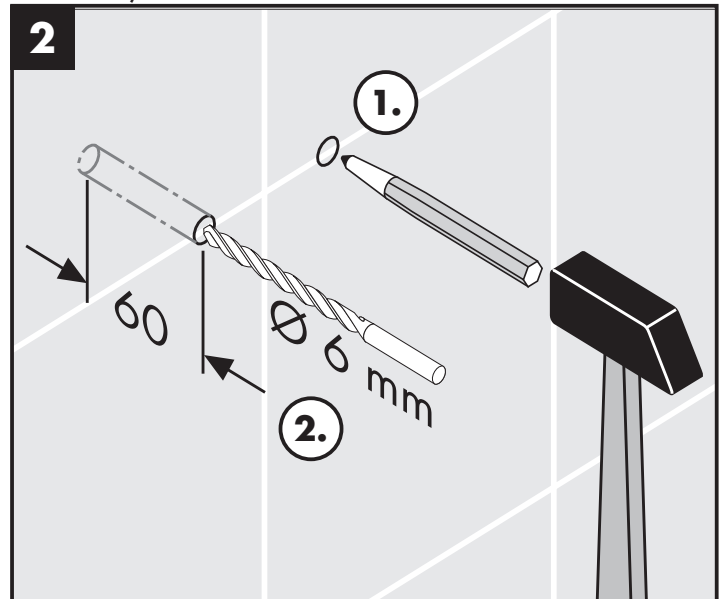
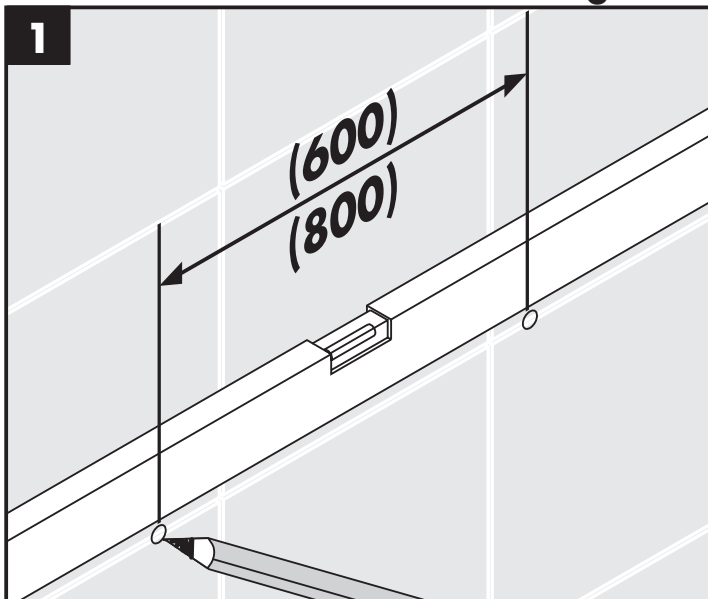

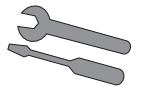

### Starck Organic 42706000 / 42708000

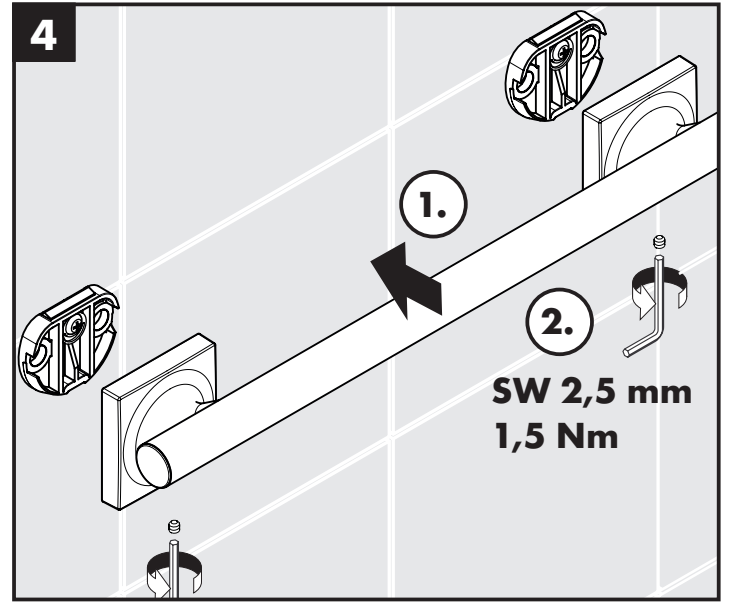
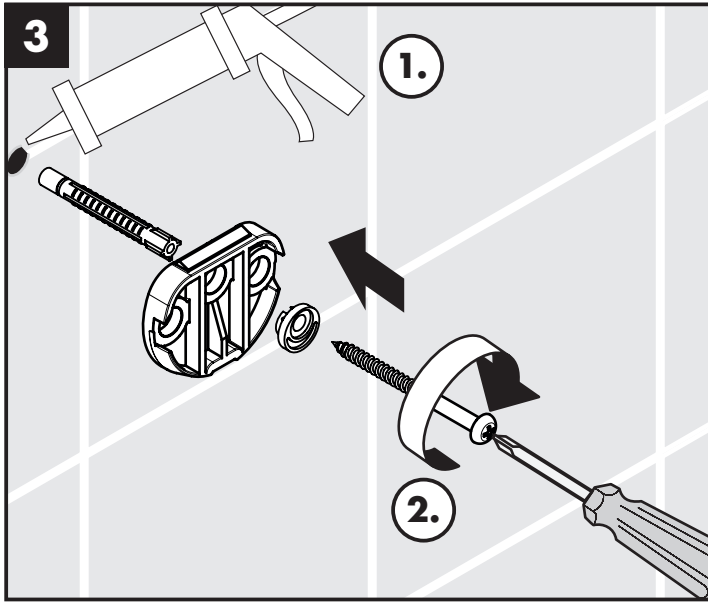

### Starck Organic 42730000

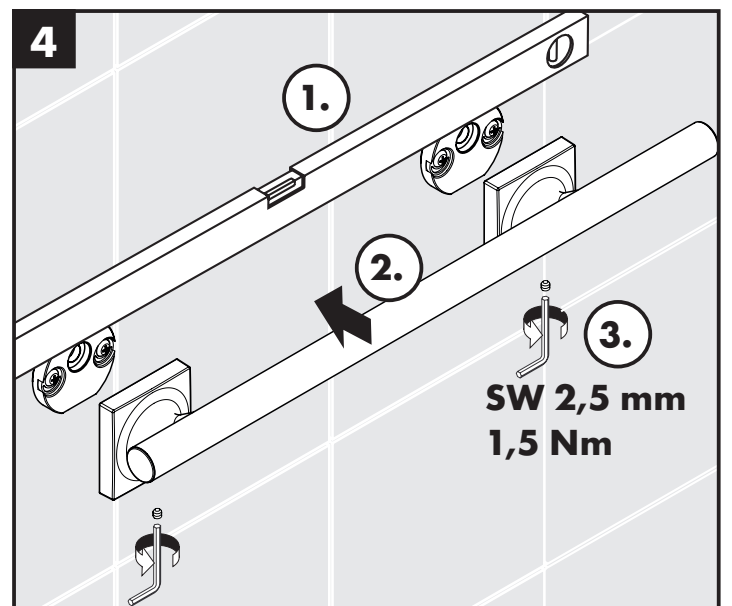
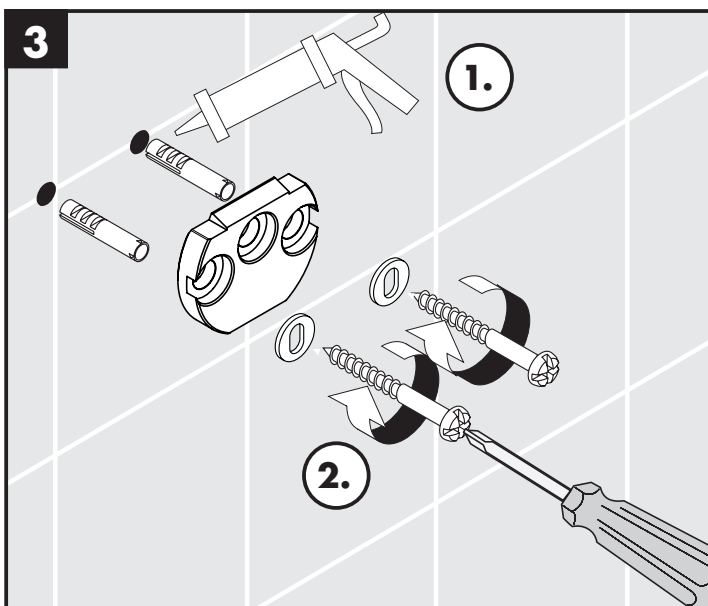
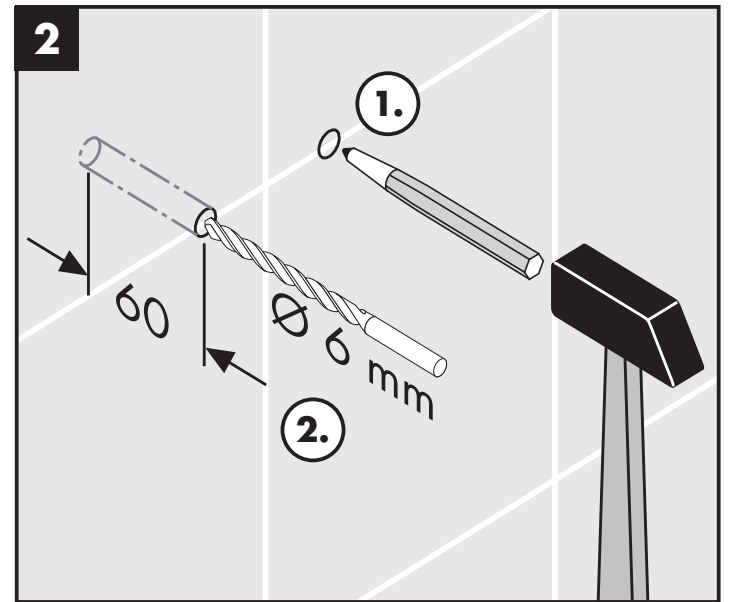
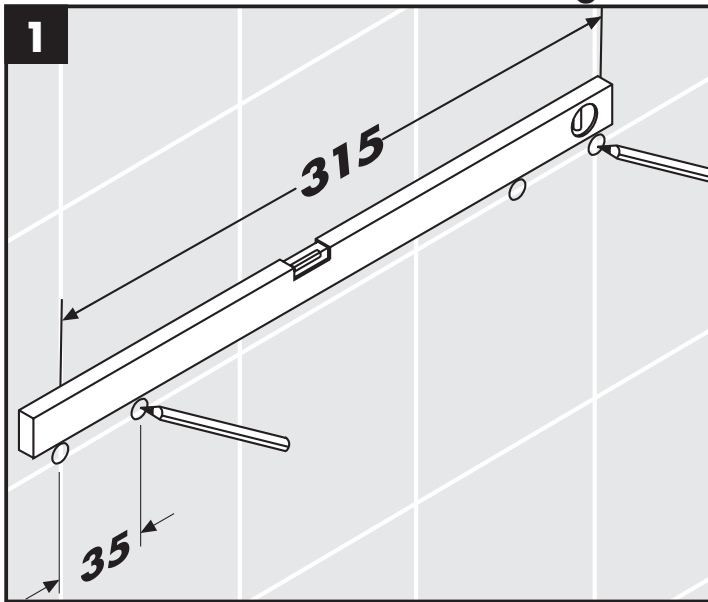

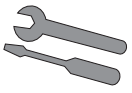

**Starck Organic 42720000**

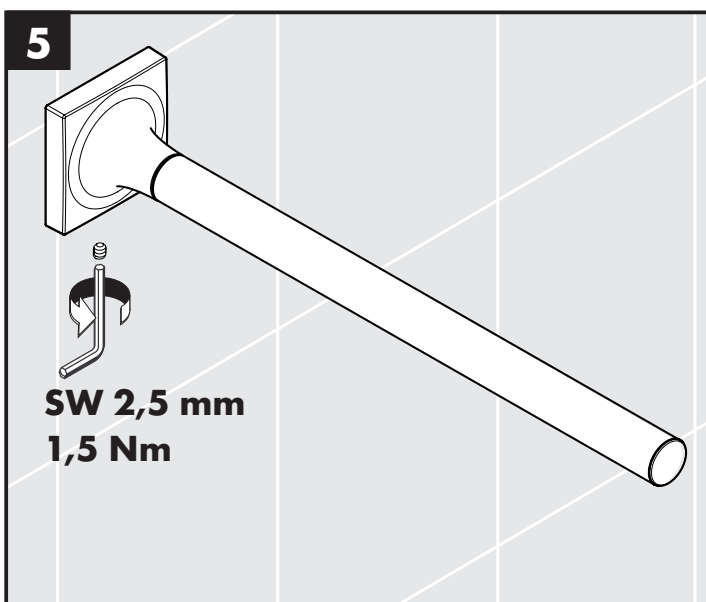
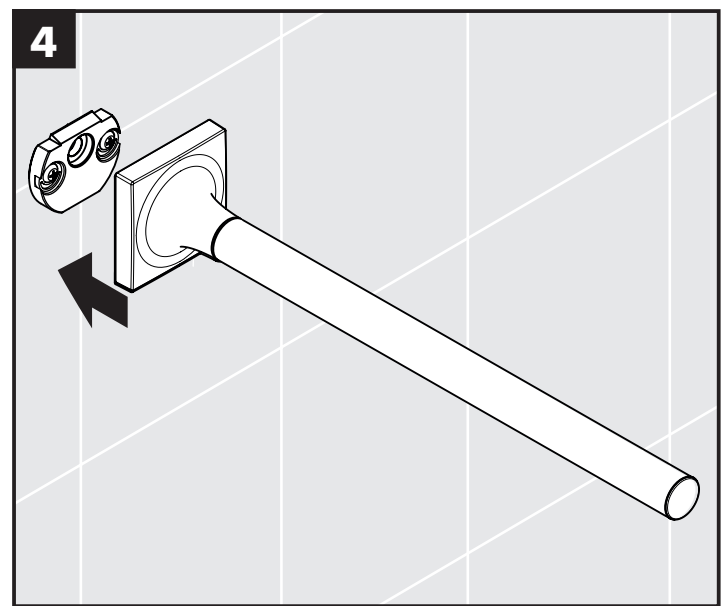
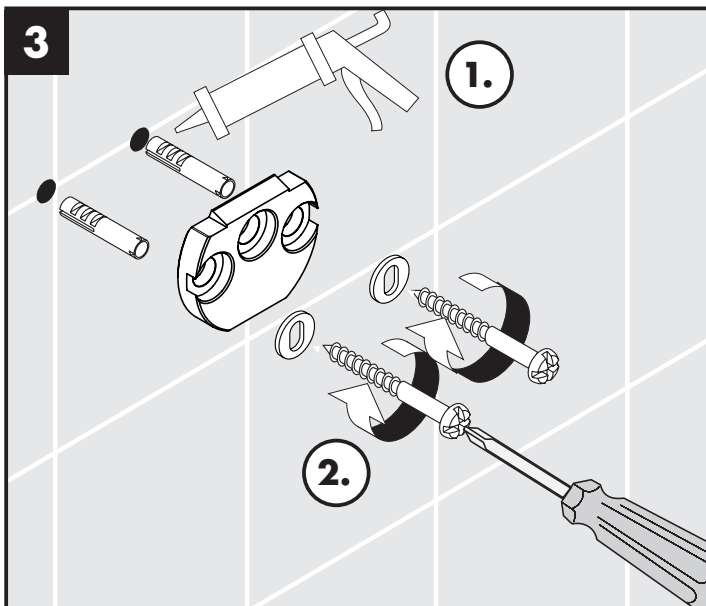
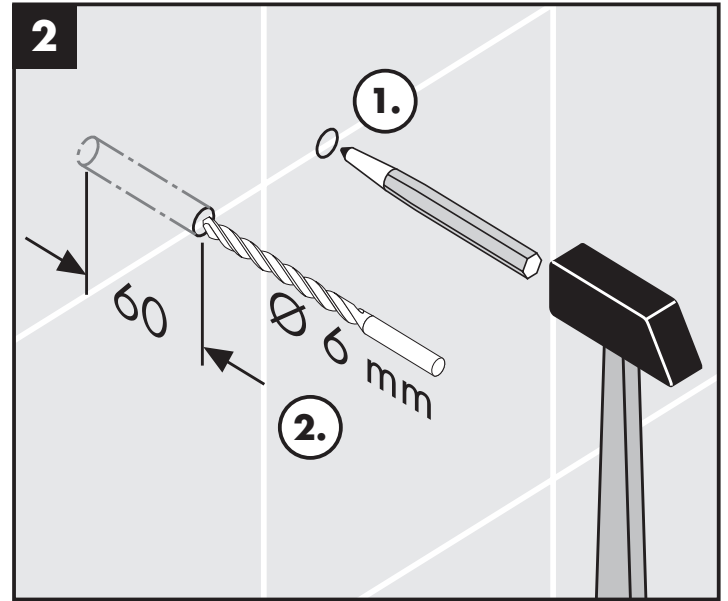
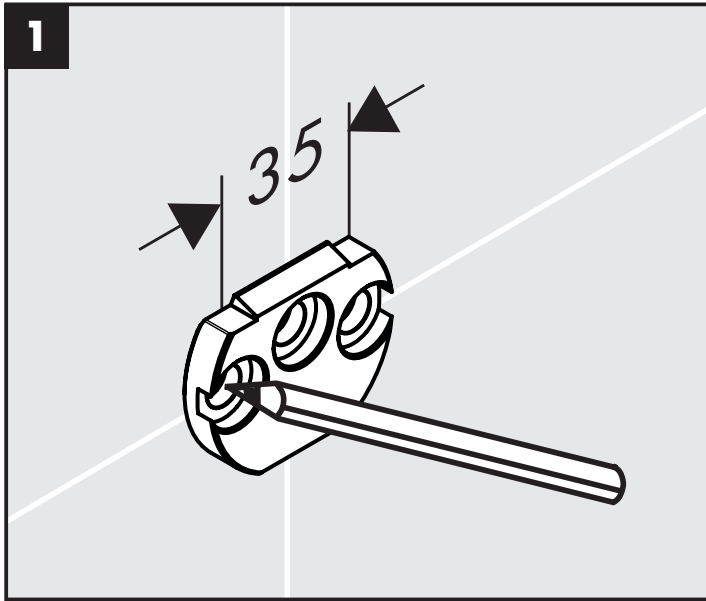

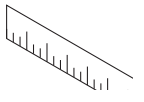

**Starck Organic**  
42737000

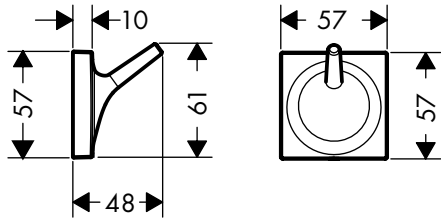

**Starck Organic**  
42733000

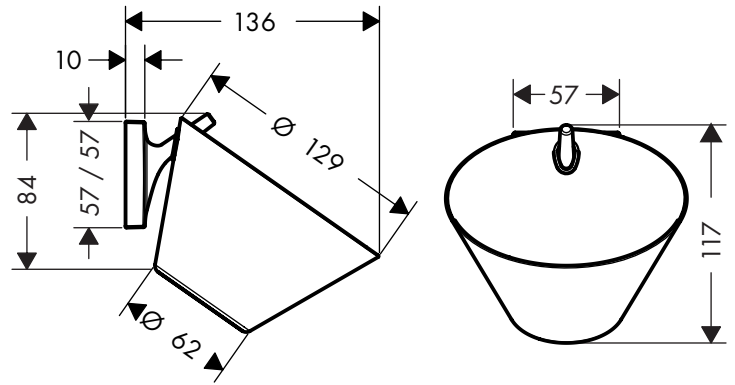

**Starck Organic**  
42730000

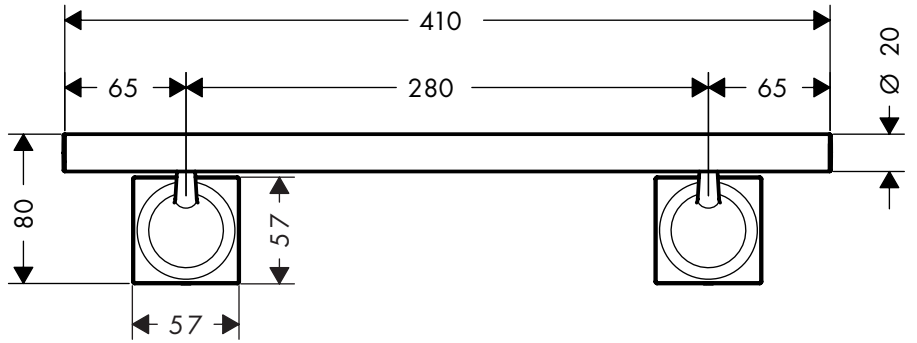
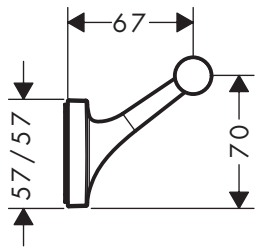

**Starck Organic**  
42706000

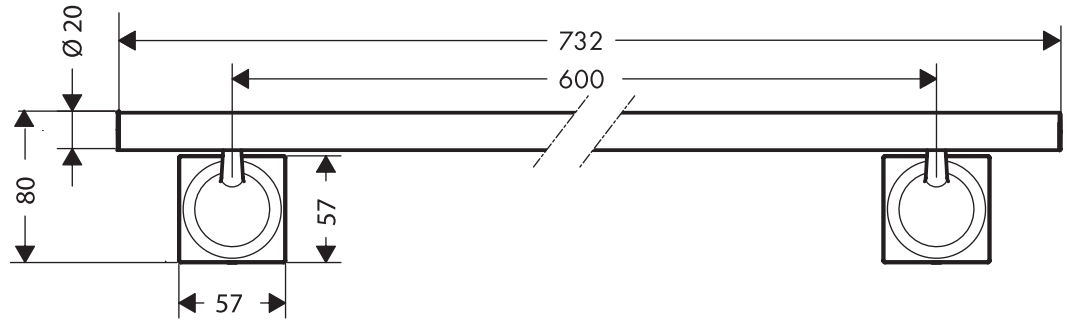
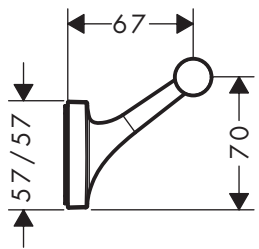

**Starck Organic**  
42708000

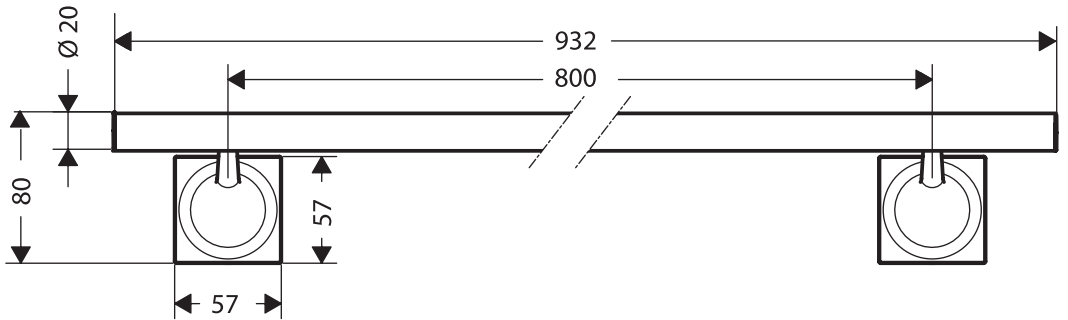
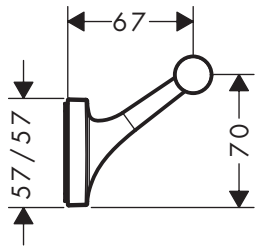

**Starck Organic**  
42736000

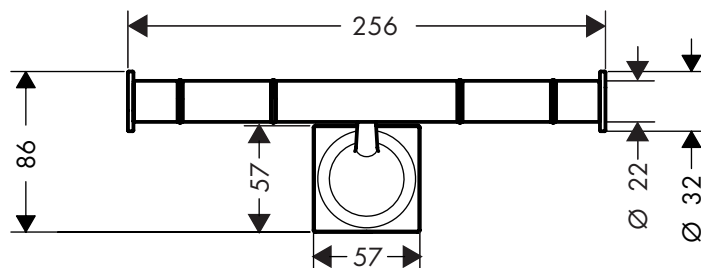
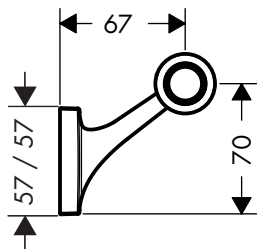

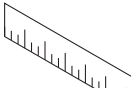

**Starck Organic**

42720000

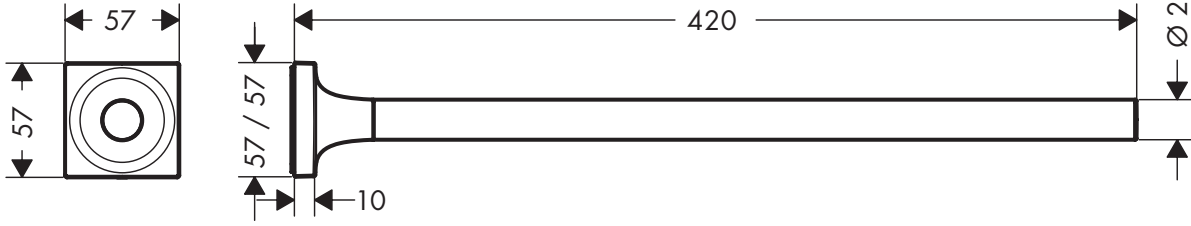

**Starck Organic**

42734000

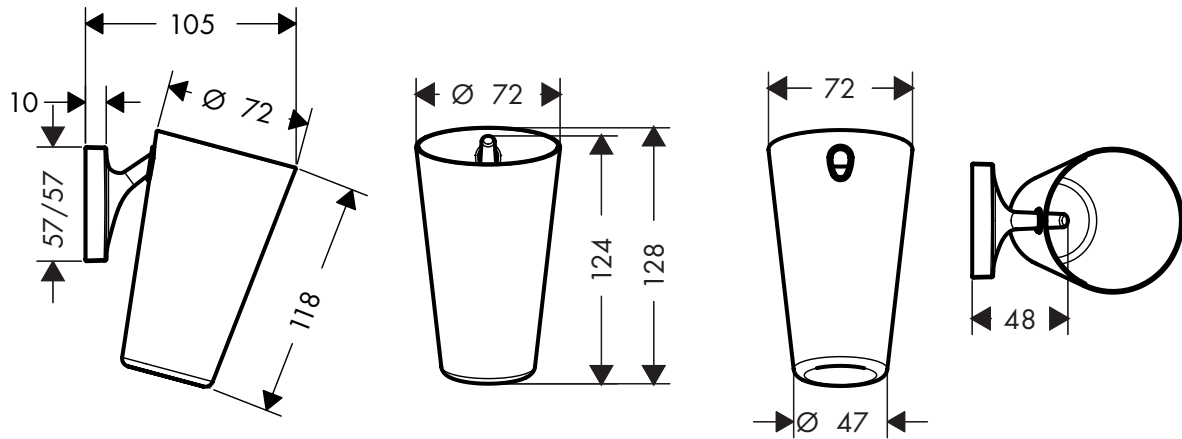

**Starck Organic**

42735000

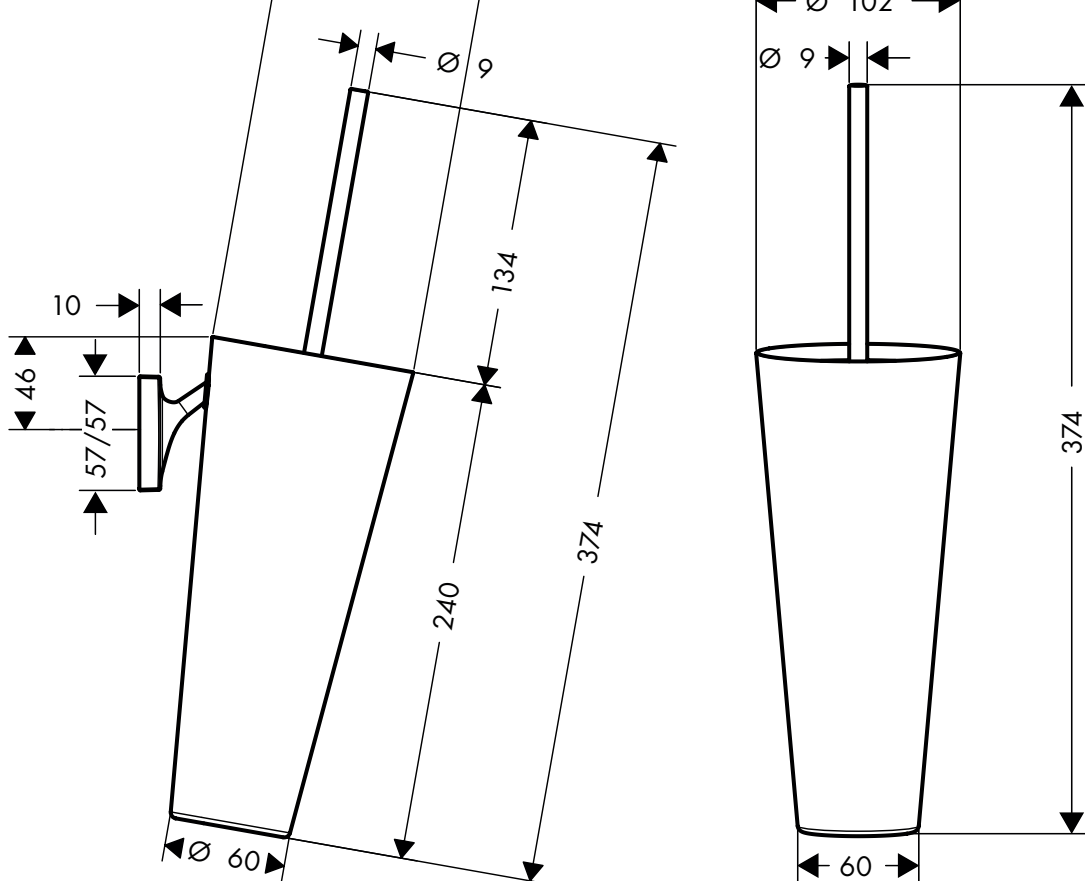





**Starck Organic**  
42730000

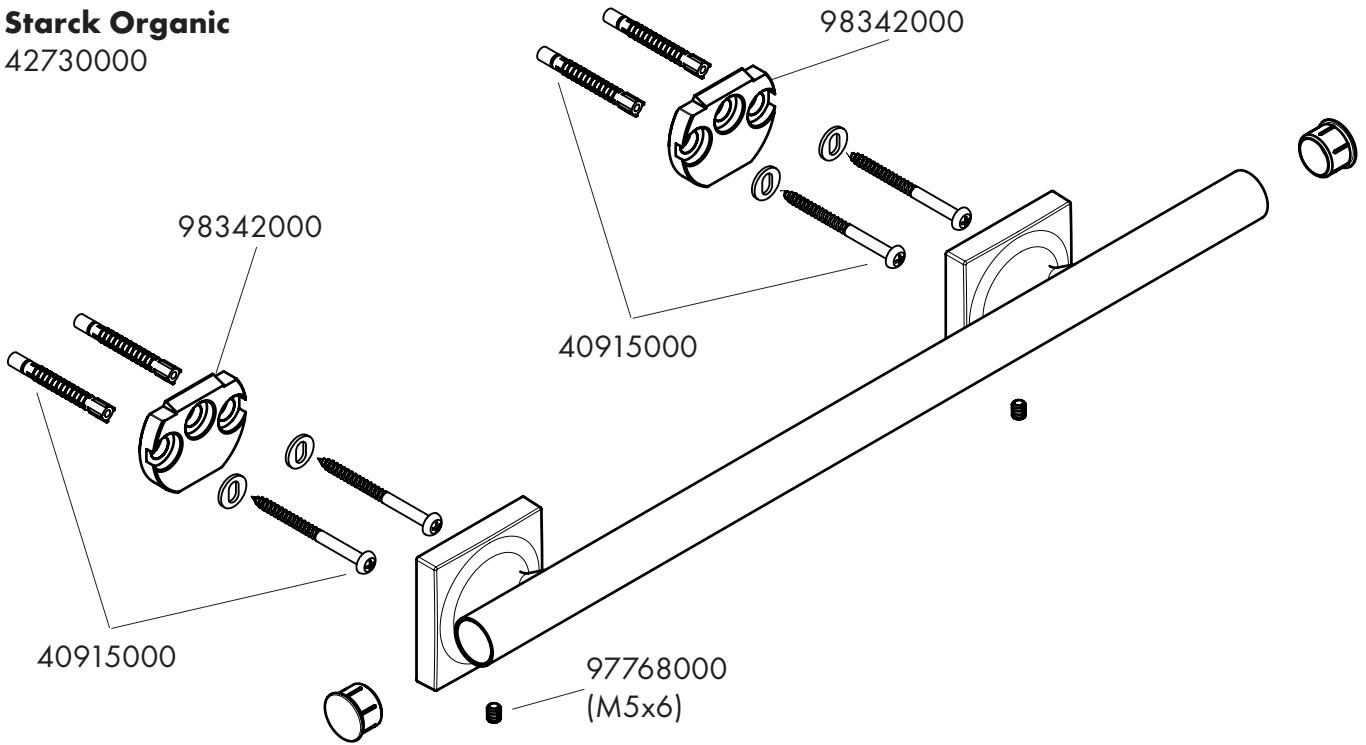

**Starck Organic**  
42706000 /  
42708000

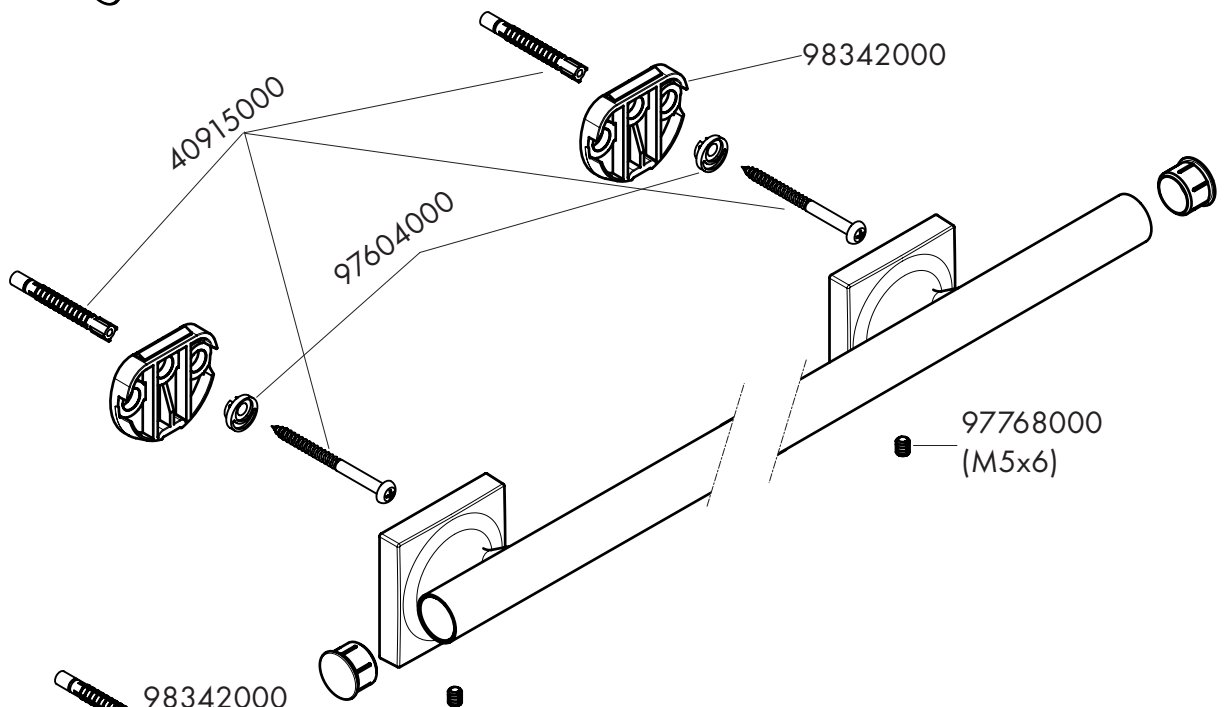

**Starck Organic**  
42736000

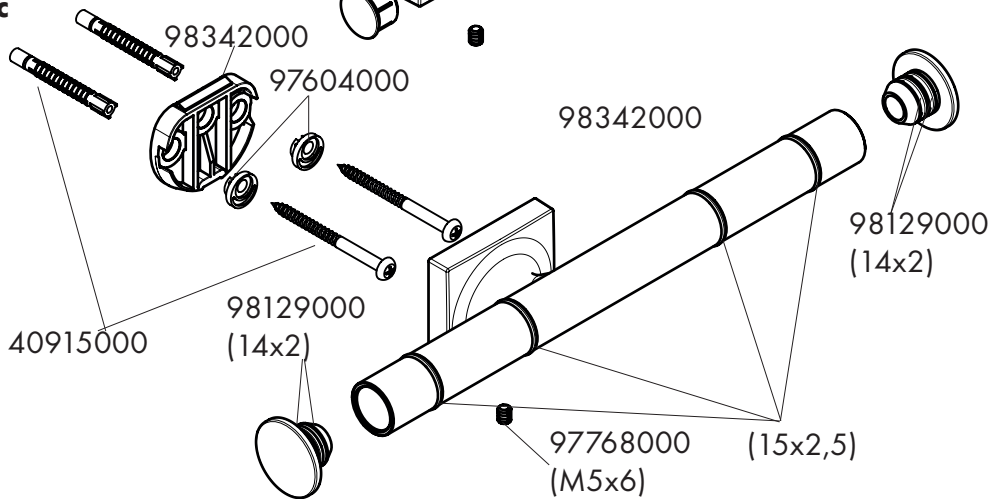



**Starck Organic**

42737000

42733000 / 42734000

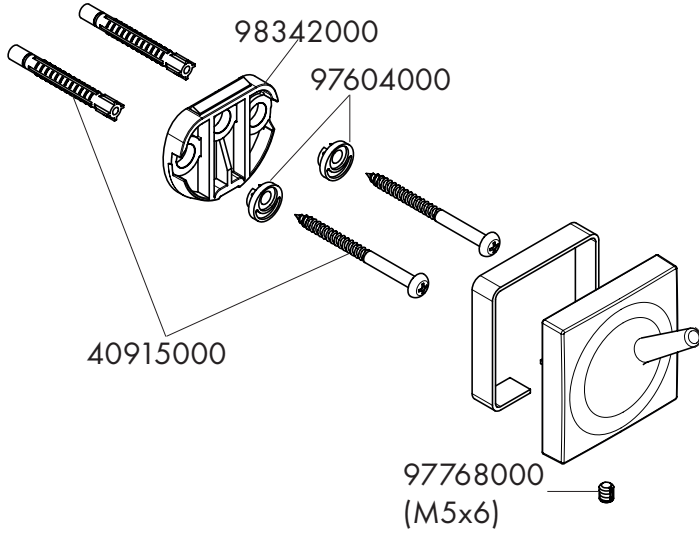

**Starck Organic**

42735000

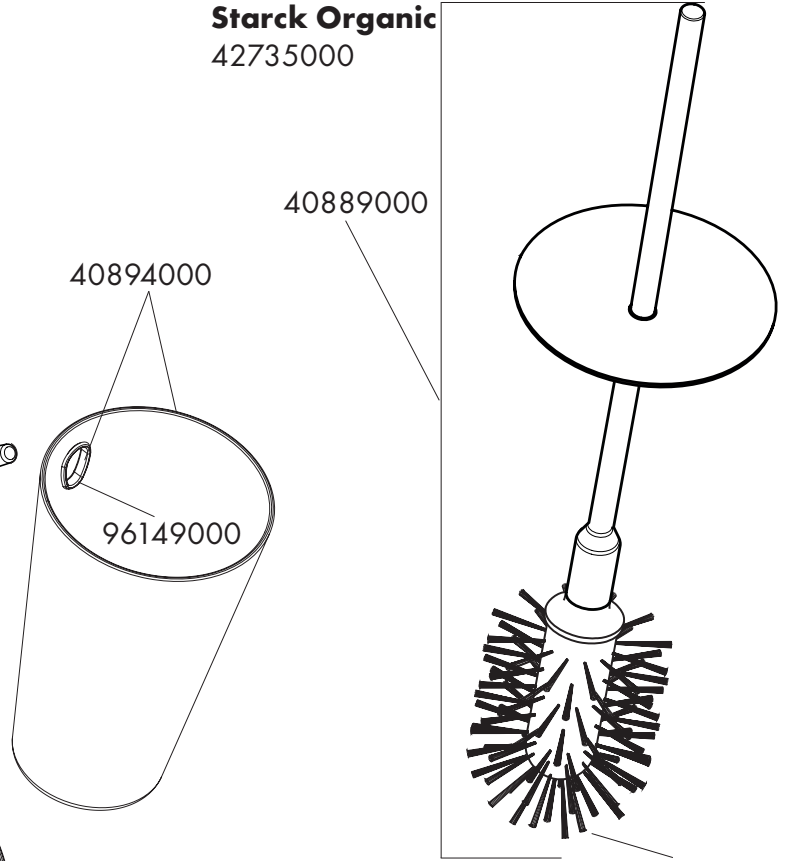

**Starck Organic**

42720000

