

CHECK EVERY COMPONENT BEFORE INSTALLATION.

1. After you open this package, please check the components in accordance with the list below.
 2. If any components are missing, please contact the local agent or our company immediately.
- Therefore, below drawing is for reference only.**

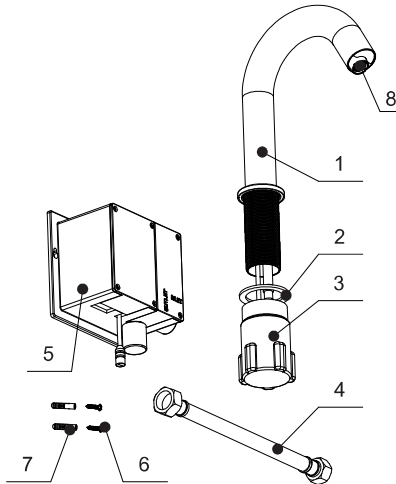

NO.	NAME	QTY
1	Faucet body	1
2	Rubber washer	1
3	Nut	1
4	Intlet hose	1
5	Main control box	1
6	Tapping screw	2
7	Wall plug	2
8	Aerator	1

IMPORTANCE FOR INSTALLATION

1. Thank you for using our high quality products. The product has been passed the functionality test before ex-factory, please do not disassemble by yourself at will.
2. The impurity must be cleared away from the inside service pipes before installation to make sure good functionality of water spray.
3. The working pressure of this product is 0.02MPa- 0.6MPa; The best water pressure is 0.1MPa-0.5Mpa. working voltage: DC 4.6V-6V; static power capacity: 0.18MW; sensor distance: 10CM; impulse width: 35ms; working water temperature: 3℃ -75℃
4. The suitable dimension of sink hole is Φ33mm~Φ38mm. The distance between hole center and wall should be over 120mm.

HELPFUL TOOLS: Spanner.

Declare: We reserve the rights to alter the structure of the product without any notice.

Assembly steps

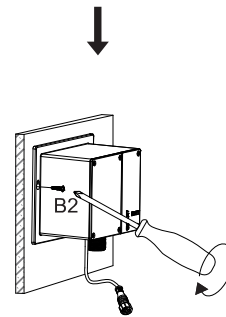
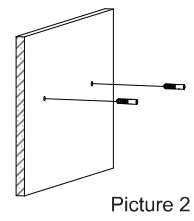
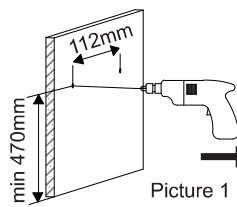
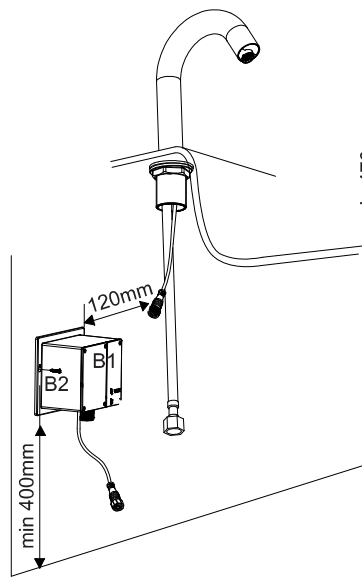
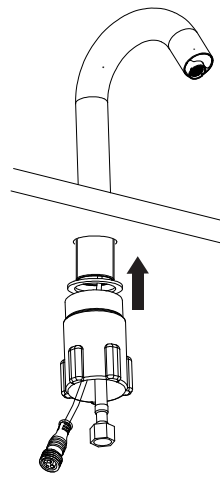
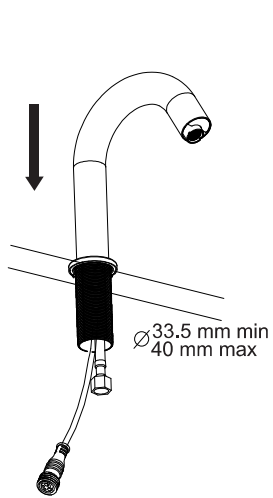

Assembly instructions

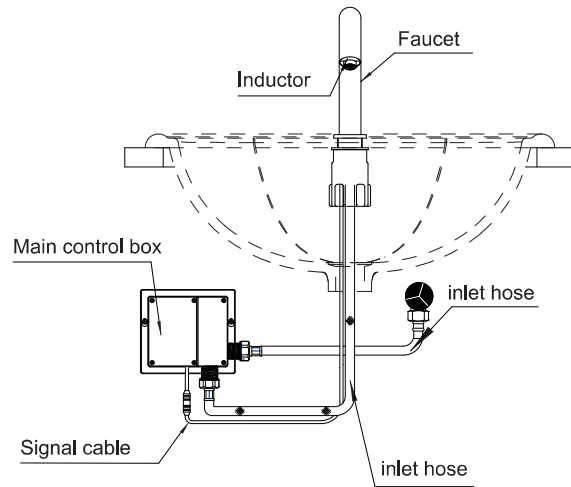

Battery assembly and replacement

1. Use the screwdriver to open the control box as shown on the diagram.
2. Put the 4 supplied battery into the battery fixture and make sure the battery positive and electronegative are positioned correctly.
3. Use good quality 4 AA alkaline battery.

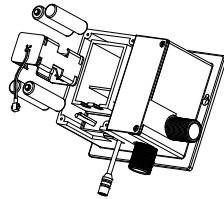

NOTE

1. Not allowed furious clash when usage so to protect the electronic circuit inside the control box.
2. Not allowed to clean and maintain the control box with direct water washer.
3. Don't put the obstacle within the faucet sensor area.

MAINTENANCE

1. Keep the product clean with clean water or mild liquid detergent regularly.
2. Rinsed up with clean water, and wiped dry with soft cotton.
3. Acid or abrasive detergents are prohibited.

