

DE	Montageanleitung	2
FR	Instructions de montage	2
EN	assembly instructions	3
IT	Istruzioni per Installazione	3
ES	Instrucciones de montaje	4
NL	Handleiding	4
DK	Monteringsvejledning	5
PT	Manual de Instalação	5
PL	Instrukcja montażu	6
CS	Montážní návod	6
SK	Montážny návod	7
ZH	组装说明	7
RU	Инструкция по монтажу	8
HU	Szerelési útmutató	8
FI	Asennusohje	9
SV	Monteringsanvisning	9
LT	Montavimo instrukcijos	10
HR	Uputstva za instalaciju	10
TR	Montaj kılavuzu	11
RO	Instrucțiuni de montare	11
EL	Οδηγία συναρμολόγησης	12
SL	Navodila za montažo	12
ET	Paigaldusjuhend	13
LV	Montāžas instrukcija	13
SR	Uputstvo za montažu	14
NO	Montasjeveiledning	14
BG	Ръководство за монтаж	15
SQ	Udhëzime rreth montimit	15
AR	تعليمات التجميع	16

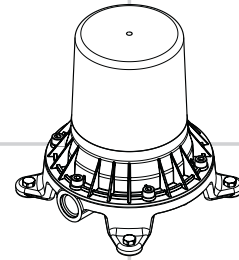

10452180

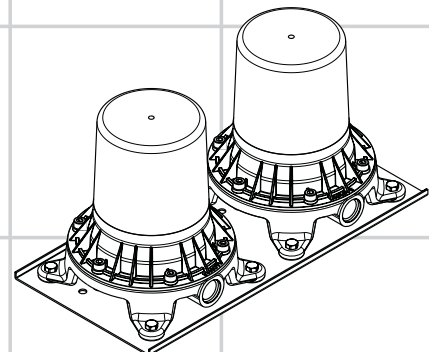

Montreux
16549180

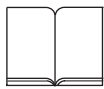

Indicaciones de seguridad

- ⚠ Durante el montaje deben utilizarse guantes para evitar heridas por aplastamiento o corte.
- ⚠ Grandes diferencias de presión en servicio entre agua fría y agua caliente deben equilibrarse.

Indicaciones para el montaje

- Antes del montaje se debe examinarse el producto contra daños de transporte. Después de la instalación no se reconoce ningún daño de transporte o de superficie.
- Los conductos y la grifería deben montarse, lavarse y comprobarse según las normas vigentes.
- Es obligatorio el cumplimiento de las directrices de instalación vigentes en el país respectivo.

Datos técnicos

Presión en servicio:	max. 1 MPa
Presión recomendada en servicio:	0,1 - 0,5 MPa
Presión de prueba:	1,6 MPa
(1 MPa = 10 bar = 147 PSI)	
Temperatura del agua caliente:	max. 70 °C
Temp. recomendada del agua caliente:	65 °C
Desinfección térmica:	max. 70 °C / 4 min

El producto ha sido concebido exclusivamente para agua potable.

Veiligheidsinstructies

- ⚠ Bij de montage moeten ter voorkoming van knel- en snijwonden handschoenen worden gedragen.
- ⚠ Grote drukverschillen tussen de koud- en warmwater-toevoer dienen vermeden te worden.

Montage-instructies

- Vóór de montage moet het product gecontroleerd worden op transportschade. Na de inbouw wordt geen transport- of oppervlakteschade meer aanvaard.
- De leidingen en armaturen moeten gemonteerd, gespoeld en gecontroleerd worden volgens de geldige normen.
- De in de overeenkomstige landen geldende installatierichtlijnen moeten nageleefd worden.

Technische gegevens

Werkdruk: max.	max. 1 MPa
Aanbevolen werkdruk:	0,1 - 0,5 MPa
Getest bij:	1,6 MPa
(1 MPa = 10 bar = 147 PSI)	
Temperatuur warm water:	max. 70 °C
Aanbevolen warm water temp.:	65 °C
Thermische desinfectie:	max. 70 °C / 4 min

Het product is uitsluitend ontworpen voor drinkwater!

Descripción de símbolos

 No utilizar silicona que contiene ácido acético!

 **Dimensiones** (ver página 17)

 De pie con revestimiento exterior.
* < 30 min. = Prolongación 60 mm
(artículo número #97686000)

 **Repuestos** (ver página 35)

 **Opcional** (no incluido en el suministro)

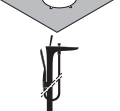
 Tira impermeabilizante #96441000
Embellecedor exterior (ver página 22)

 **Marca de verificación** (ver página 17)

Montaje
ver página 18

Symboolbeschrijving

 Gebruik geen zuurhoudende silicone!

 **Maten** (zie blz. 17)

 Vrijstaand badkuip met buitenmantel.
* < 30 min. = Verlengstuk 60 mm
(Artikelnummer #97686000)

 **Service onderdelen** (zie blz. 35)

 **Toebehoren** (behoort niet tot het leveringspakket)

 dichtmanchet #96441000
Kleurset (zie blz. 22)

 **Keurmerk** (zie blz. 17)

Montage
zie blz. 18

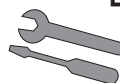

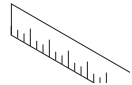

10452180

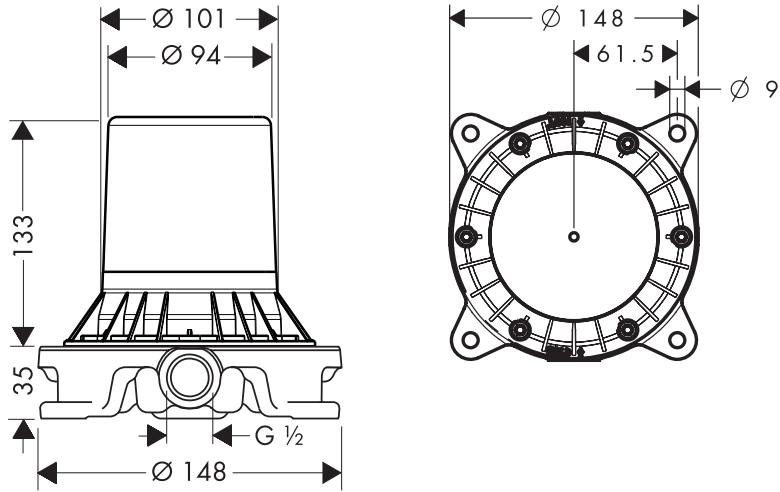

Montreux
16549180

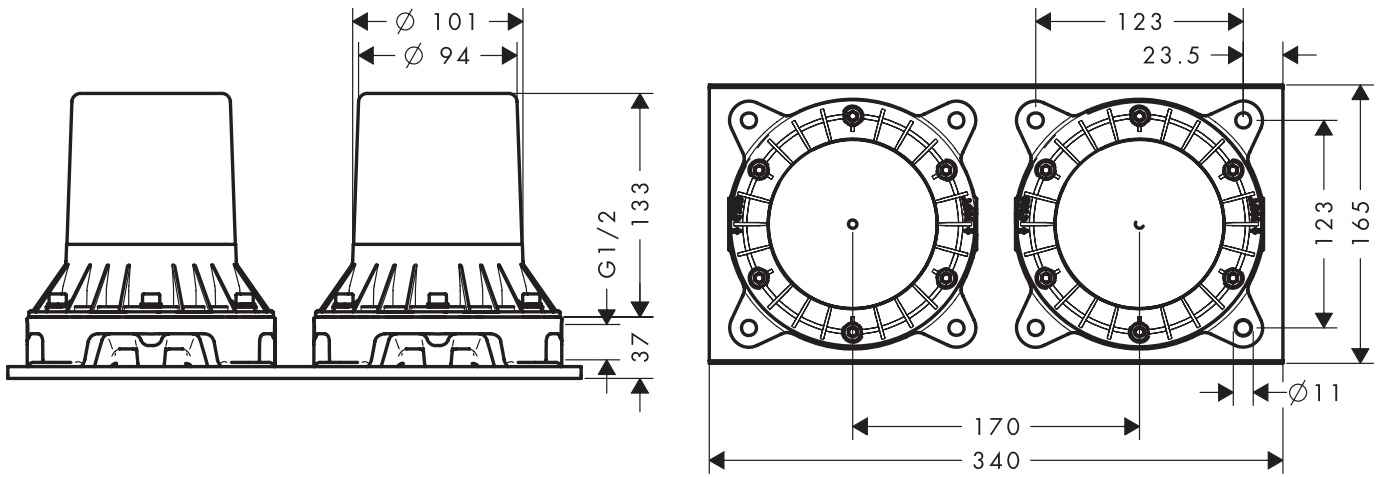

	P-IX	DVGW	SVGW	WRAS	KIWA	NF	ACS	ETA
10452180			X	X				ETA 1.42/19030
16549180			X					

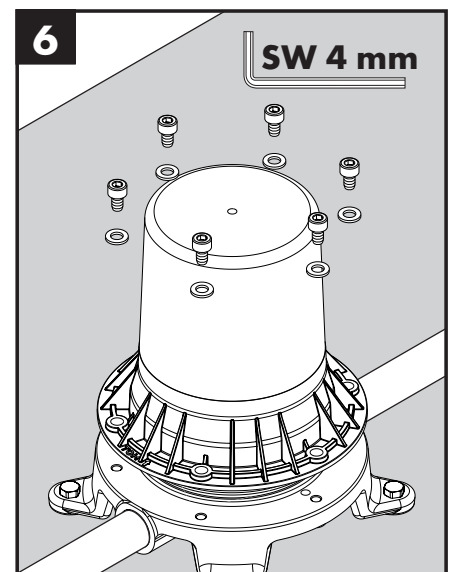
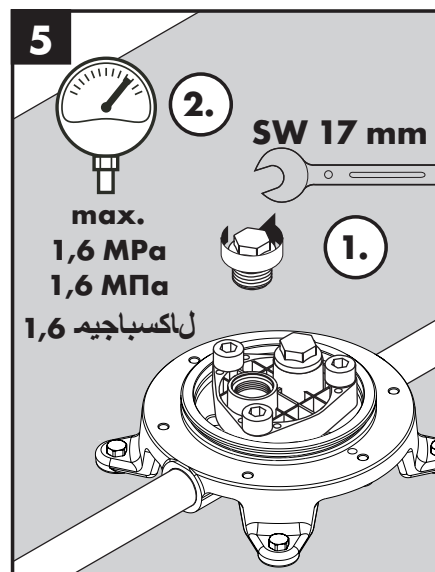
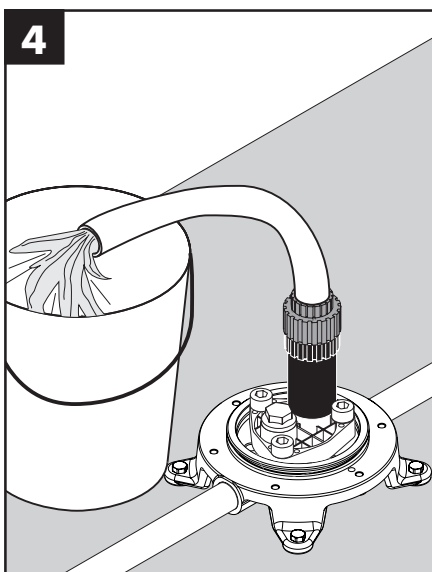
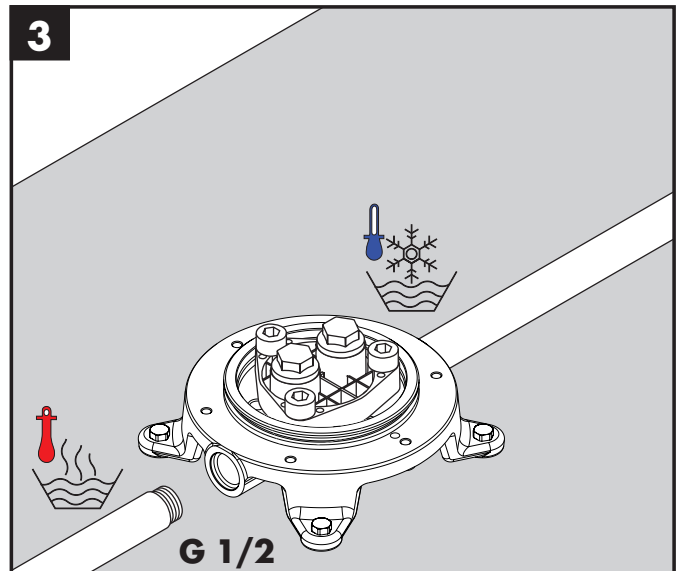
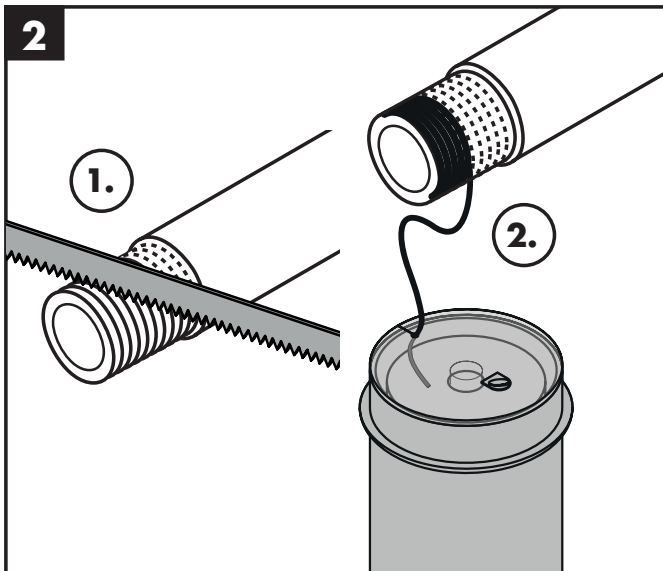
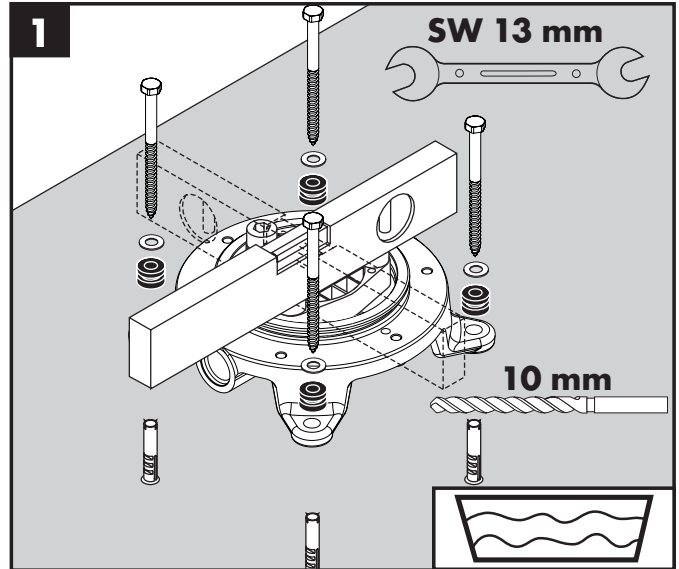
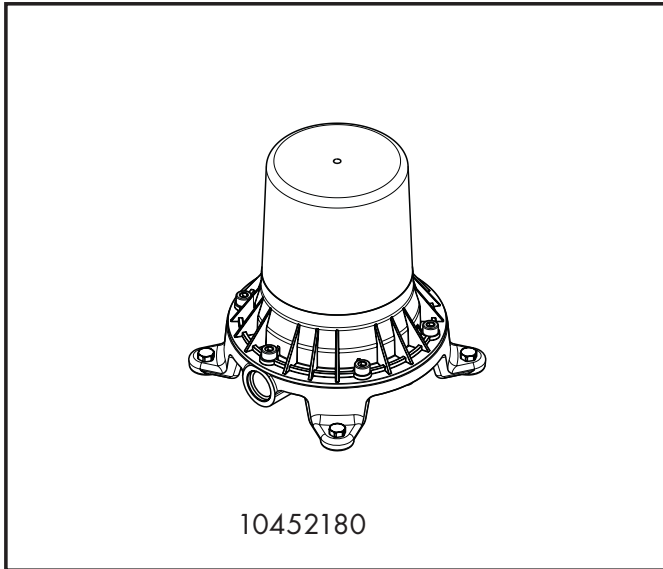
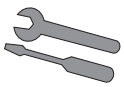

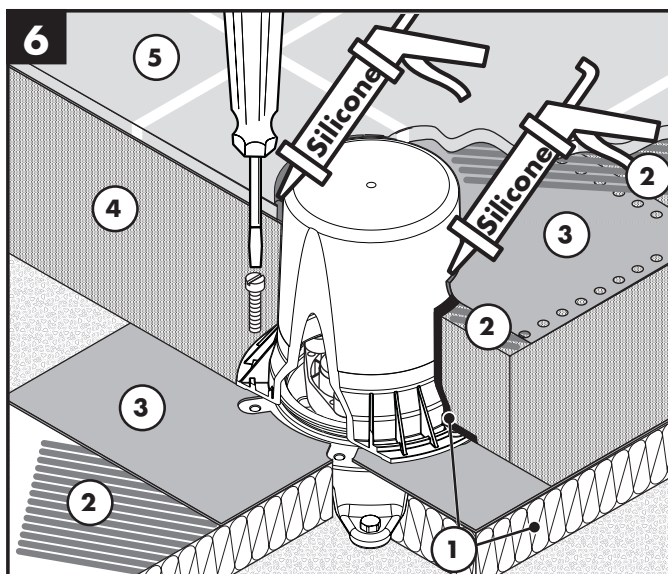
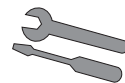

1 Isolierung / Les bandes / d'isolation / Cardboard strips / Strisce di cartone / Cortar las tiras de cartón / izolatie / Isolering / Tiras de cartão / Izolace / Izolácia / 保温层 / Изоляция / Szigetelés / Eristys / Isolering / Izoliacija / Izolacija / İzolasyon / İzolație / Μόνωση / Izolacija / Isolatsioon / Izolācija / Izolacija / Isolasjon / Изоляция / Izolimi / عزل

2 Kleber / Colle / Glue / Colla / Pegamento / Lijm / Lim / Cola / Klej / Lepidlo / Lepidlo / 胶水 / Клей / Ragasztó / Liima / Lim / Klijai / Lijepak / Υαρίστρις / Adeziv / Κόλλα / Lepilo / Liim / Lime / Lepak / Klebemiddel / Лепило / Ngjitësi / مادة لاصقة

3 optional erhältlich Dichtmanschette / une lamelle disponible en option / if necessary, please order sealing foil separatly / disponibile in opzione guarnizione a flangia / tira impermeabilizante opcional / optioneel verkrijgbare dichtmanchet / efter ønske fås en tætningsmanchet / se necessário, por favor encomende a película de vedação separadamente / Opcjonalnie dostępna uszczelka mocująca / orčně dostupná těsnicí manžeta / v prípade potreby objednať tesniacu manžetu / 视需要, 单独订购密封箔 / манжета, предлагаемая дополнительно / opcionalisan kapható tömitőkarima / Lisävarusteena saatava tiivisterengas / tätningmanschett finns som tillval / jei būtina, galima užsakyti sandariklius / Manžete za brtvljenje - mogu se naručiti prema želji / İsteğe bağlı temin edilebilen sızdırmazlık manşeti. / manşetâ de etanşare opşională / προαιρετικό στεγανοποιητικό παρέμβυσμα / Tesnilna manžeta je dobavljiva posebej. / Važadusel tellige eraldi tihend / Atsevišķi pasūtāma blīvējuma uzmava / Zapřívne manžetne - mogu se naručiti prema želji / opşjonal tilgjengelig tetningsmansjett / уплътнителен маншет, който може да се получи като опция / manshetë izoluese opcionale / إذا لزم الأمر، يرجى طلب رقيقة معدنية مانعة للتسرب بشكل منفصل

4 Estrich / Cement floor / Cement floor / Impasto adesivo / Enlucido / Afschilderlaag / Dekvloer / Cementgulv / Pavimento / Dlažba / Dlažba / 抹灰 / Бесшовный пол / Esztrich / Seinäpinta / Golvbeläggning / Grindys / Estrih / Şap / Şapă / Τιμεντοκονία / Estrih / Kivipõrand / Klons / Estrih / Sementgulv / Циментов под / Трапазани / ملاط الحائط

5 Fliesen / Carrelage / Tiles / Piastrelle / Baldosas / Tegels / Flieser / Azulejos / Płytki / Dlażdce / Dlażdce / 瓷砖 / Плитка / Csempe / Laatta / Kakel / Plytelés / Pločice / Fayans / Gresie / Πλακίδια / Ploščice / Plaat / Flizes / Pločice / Fliser / Плочки / Plakat e murit / بلاطات

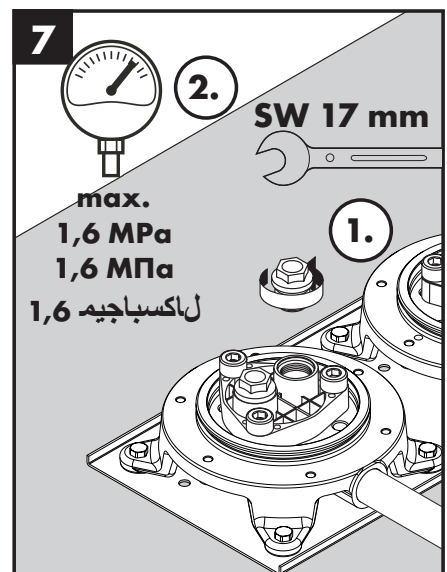
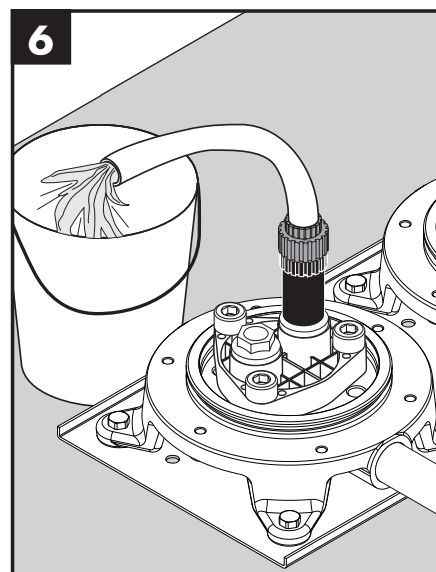
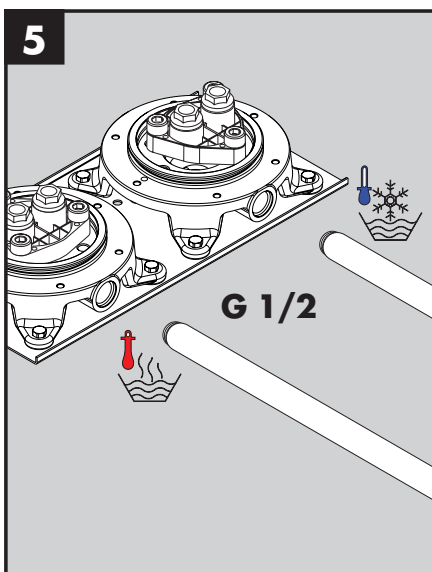
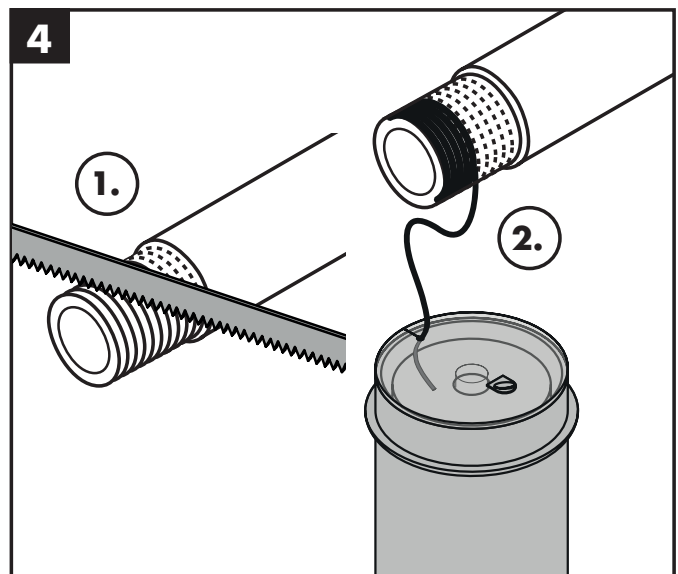
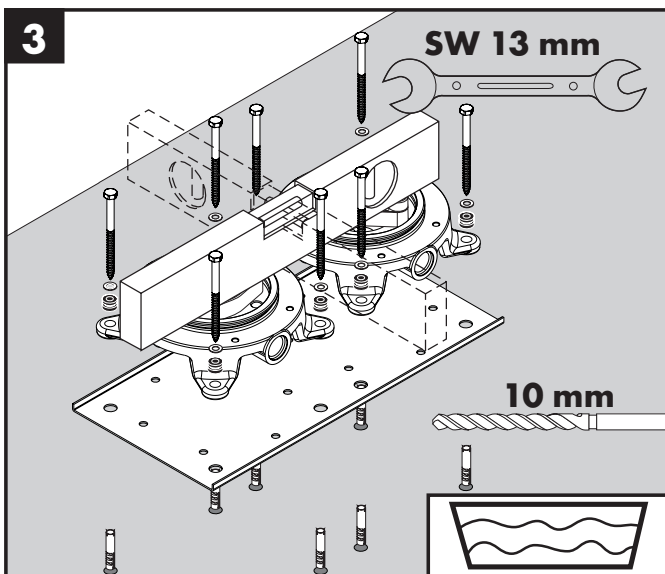
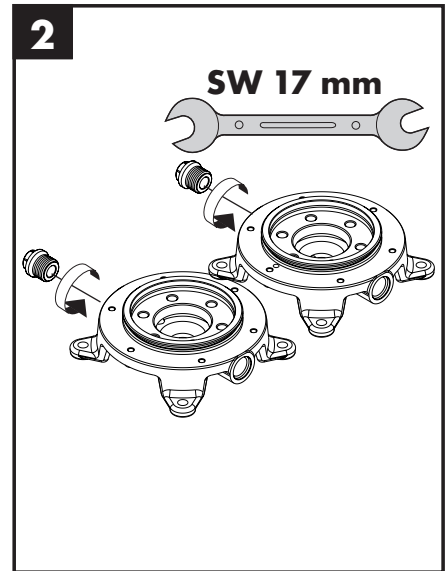
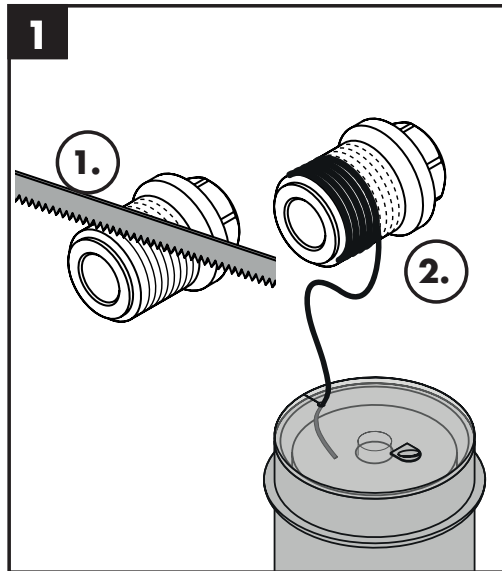
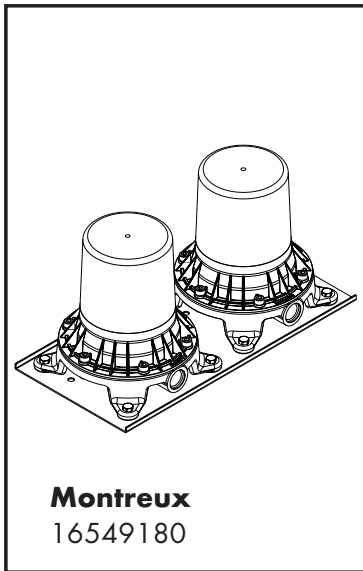
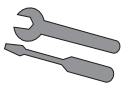

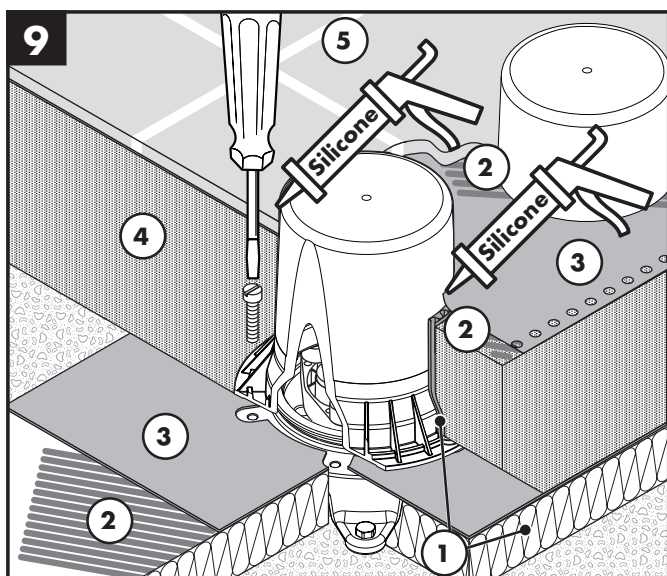
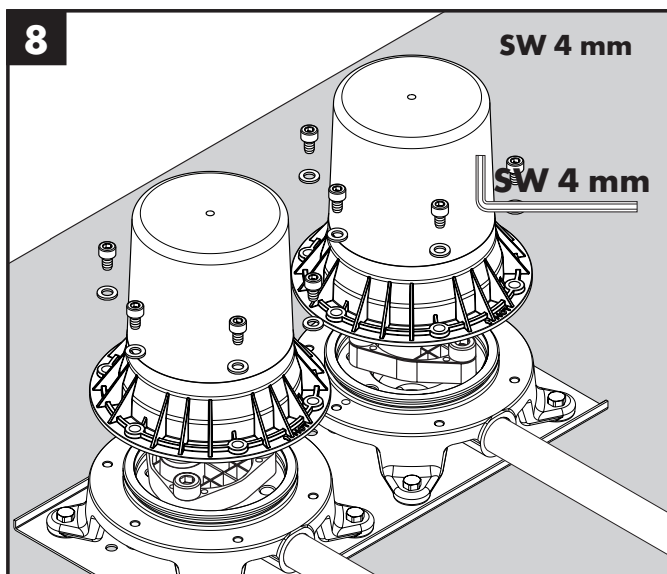
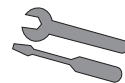

- 3 optional erhältlich Dichtmanschette / une lamelle disponible en option / if necessary, please order sealing foil separately / disponibile in opzione guarnizione a flangia / tira impermeabilizante opcional / optioneel verkrijgbare dichtmanchet / efter ønske fås en tætningsmanchet / se necessário, por favor encomende a película de vedação separadamente / Opcjonalnie dostępna uszczelka mocująca / oprčně dostupná těsnicí manžeta / v prípade potreby objednať tesniacu manžetu / 视需要, 单独订购密封箔 / манжета, предлагаемая дополнительно / opcionálisan kapható tömitőkarima / Lisävarusteena saatava tiivisterengas / tättningsmanschett finns som tillval / jei būtina, galima užsakyti sandariklius / Manžete za brtvljenje - mogu se naručiti prema želji / Istege bađli temin edilebilen sızdırmazlık manşeti. / manşetâ de etanşare opțională / προαιρετικό στεγανοποιητικό παρέμβυσμα / Tesnilna manšeta je dobavljiva posebej. / Vajadusel tellige eraldi tihend / Atsevišķi pasūtāma blīvējuma uzmaiva / Zapřitvne manžetne - mogu se naručiti prema želji / opsjonal tilgjengelig tetningsmansjett / уплотнителен маншет, който може да се получи като опция / manshetë izoluese opcionale / إذا لزم الأمر، يرجى طلب رقيقة معدنية مانعة للتسرب بشكل منفصل

- 1 Isolierung / Les bandes / d'isolation / Cardboard strips / Strisce di cartone / Cortar las tiras de cartón / isolatie / Isolering / Tiras de cartão / Izolace / Izolácia / 保温层 / Изоляция / Szigetelés / Eristys / Isolering / Izolacija / Izolacija / İzolasyon / Izolajie / Μόνωση / Izolacija / Isolatsioon / Izolācija / Izolacija / Isolasjon / Изоляция / Izolimi / عزل
- 2 Kleber / Colle / Glue / Colla / Pegamento / Lijm / Lim / Cola / Klej / Lepidlo / Lepidlo / 胶水 / Клей / Ragasztó / Liima / Lim / Klijaj / Lijepak / Yarıstırıcı / Adeziv / Κόλλα / Lepilo / Liim / Lime / Lepak / Klebemiddel / Лепило / Ngjitiësi / تمادة لاصقة

- 4 Estrich / Cement floor / Cement floor / Impasto adesivo / Enlucido / Afschilderlaag / Dekvloer / Cementguld / Pavimento / Dlažba / Dlažba / 抹灰 / Бесшовный пол / Esztrich / Seinäpinta / Golvbeläggning / Grindys / Estrih / Şap / Şapă / Τιμεντοκονία / Estrih / Kivipõrand / Klons / Estrih / Sementgulv / Циментов под / Trapezani / بلاط الحائط
- 5 Fliesen / Carrelage / Tiles / Piastrelle / Baldosas / Tegels / Flieser / Azulejos / Płytki / Dlaždice / Dlaždice / 瓷砖 / Плитка / Csempe / Laatta / Kakel / Plytelés / Pločice / Fayans / Gresie / Πλακίδια / Ploščice / Plaat / Flizes / Pločice / Fliser / Плочки / Plakat e murit / بلاطات



Starck X
10406000

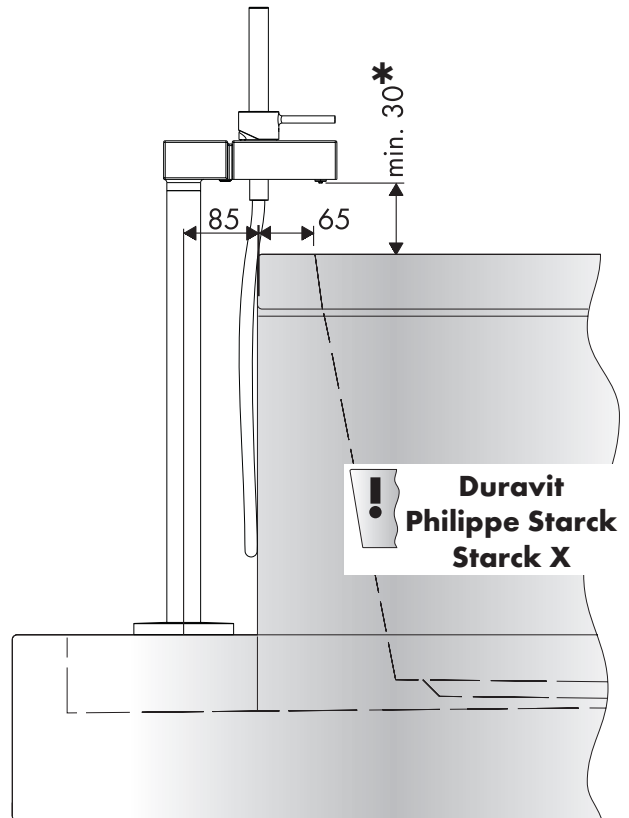
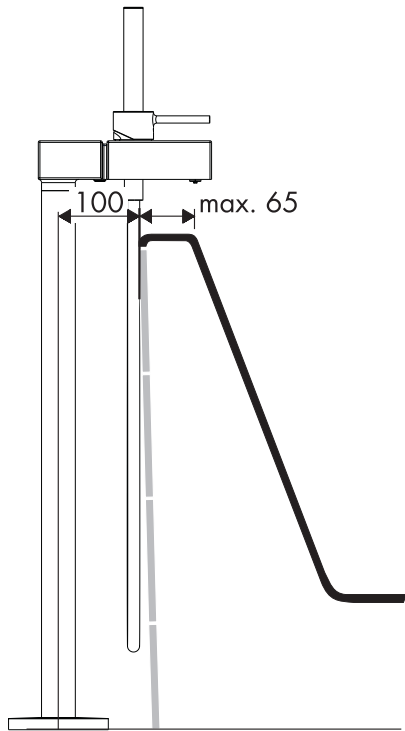
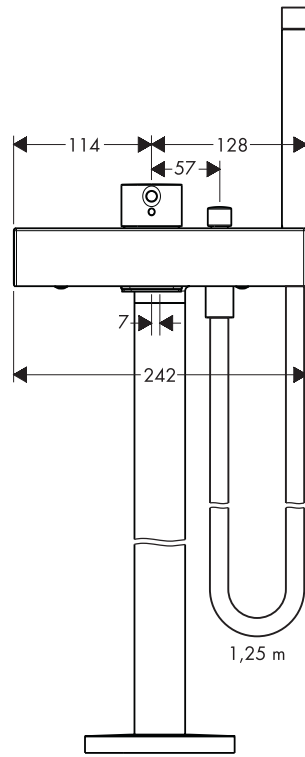
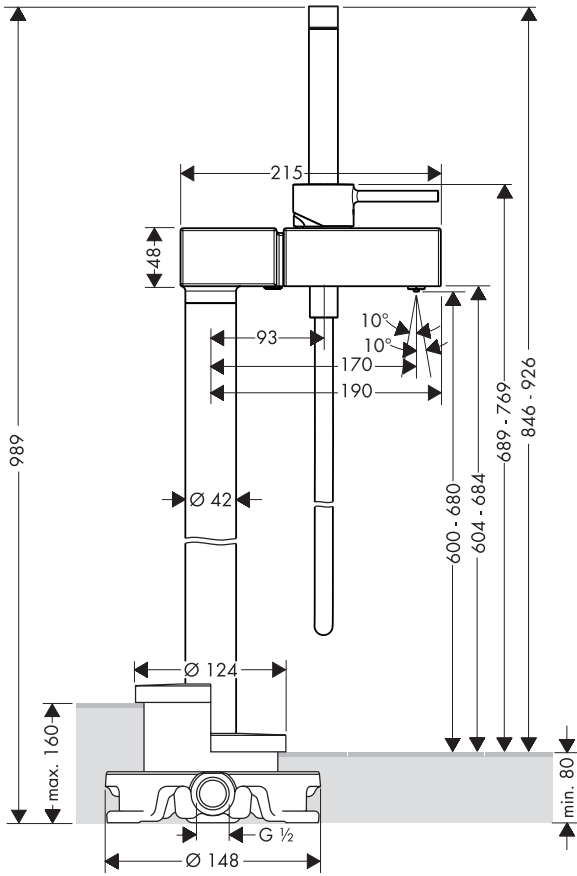

Starck
10458000

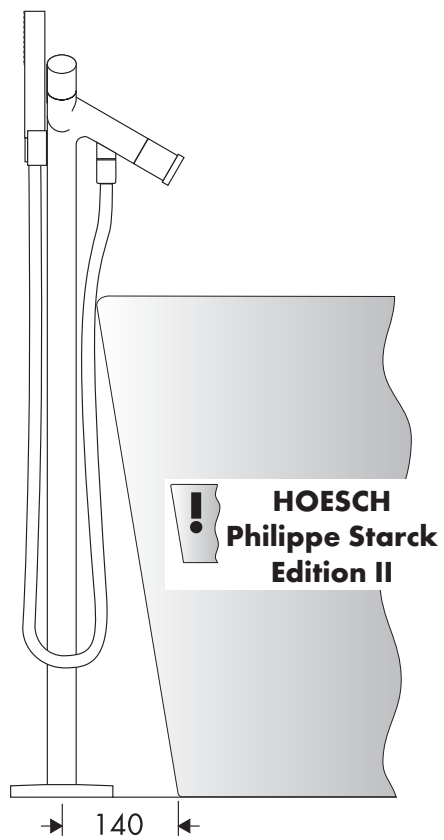
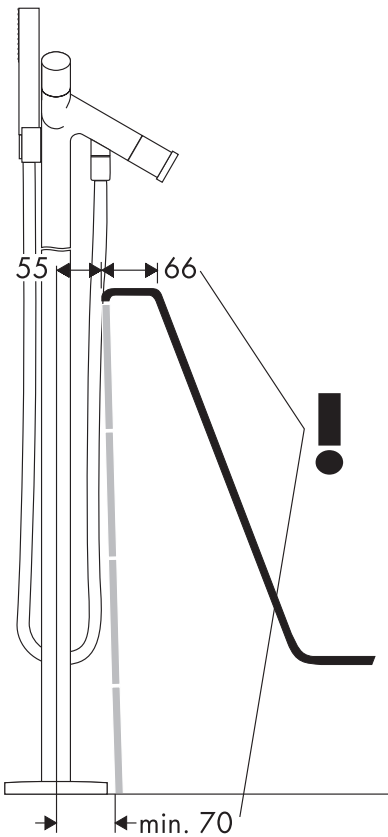
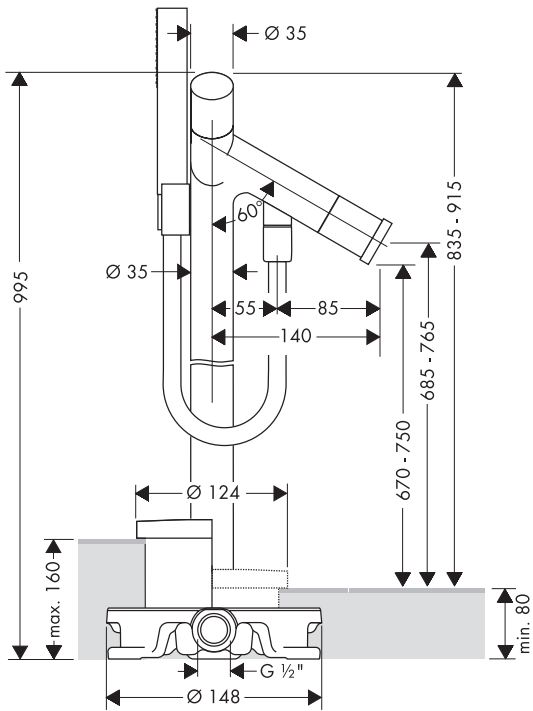



Starck
10456000

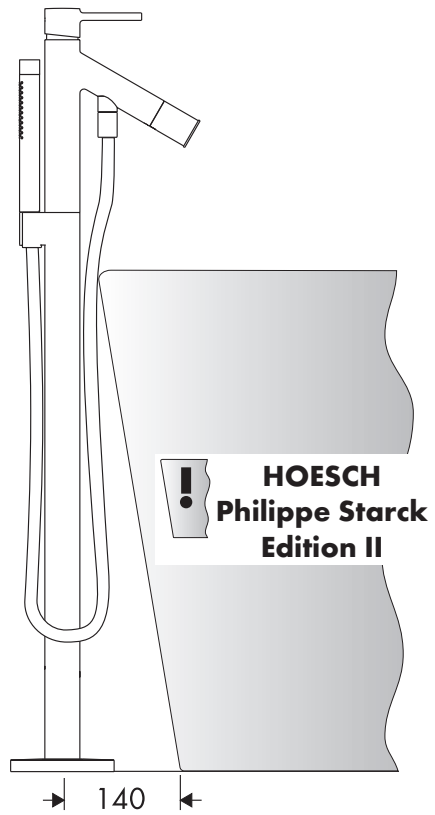
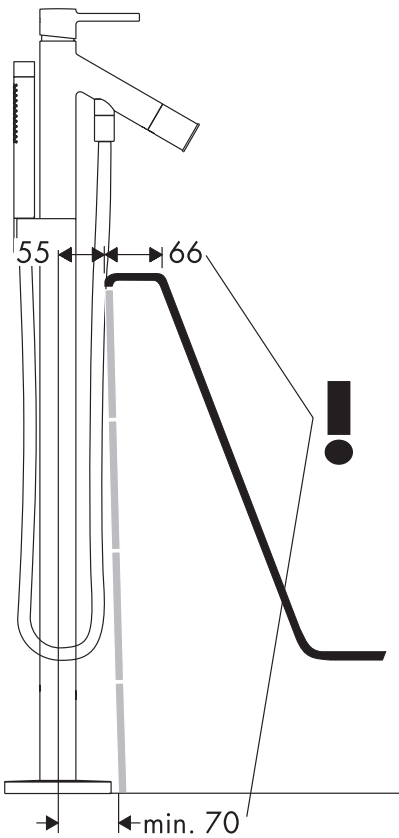
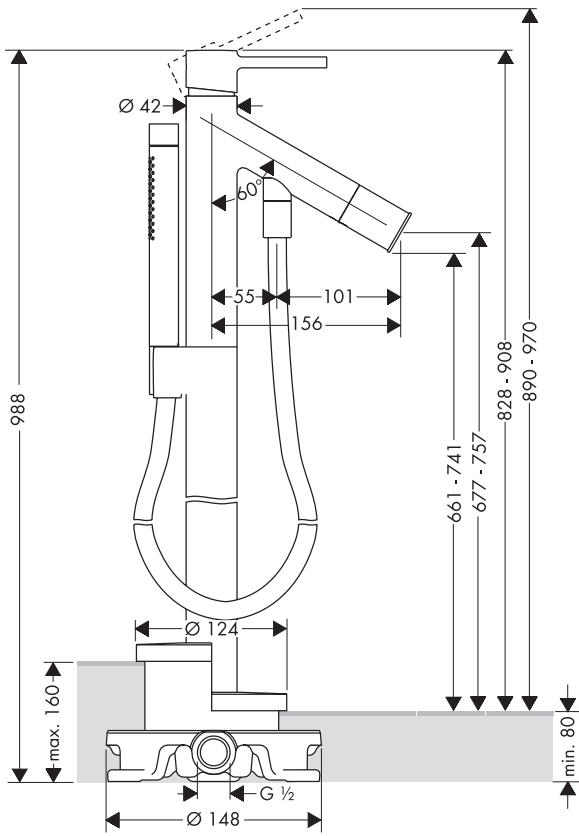

Urquiola
11422000

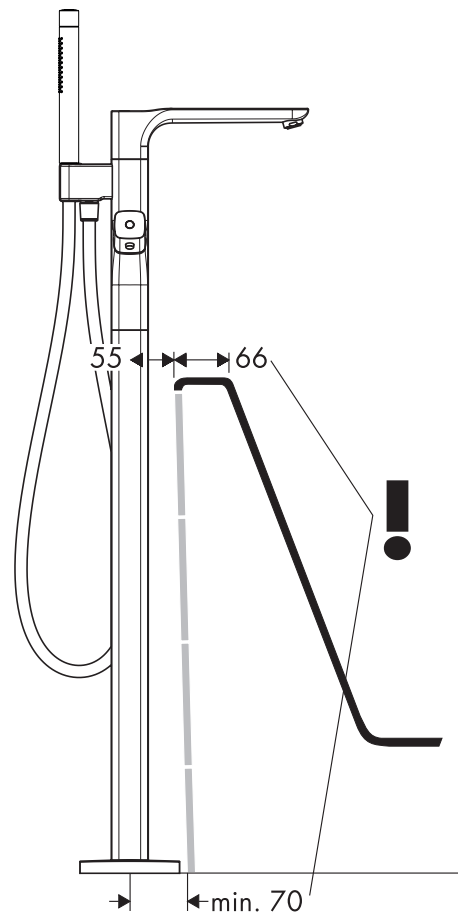
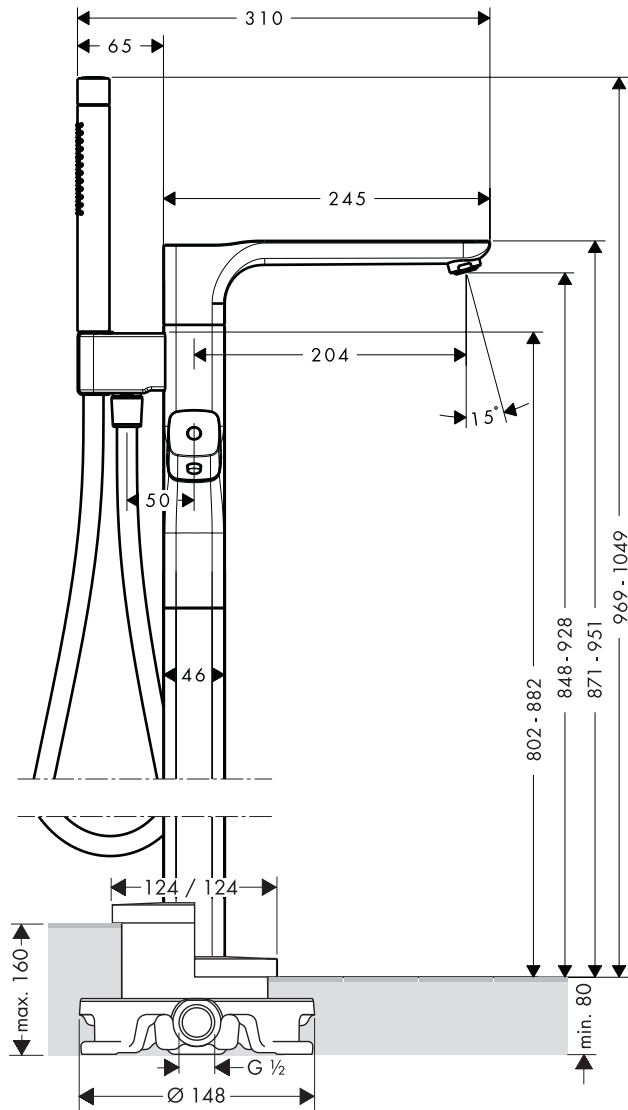



Starck Organic
12016000

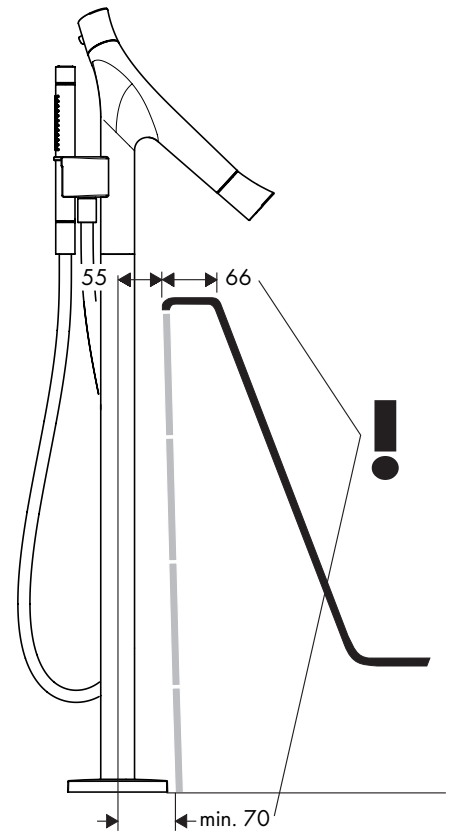
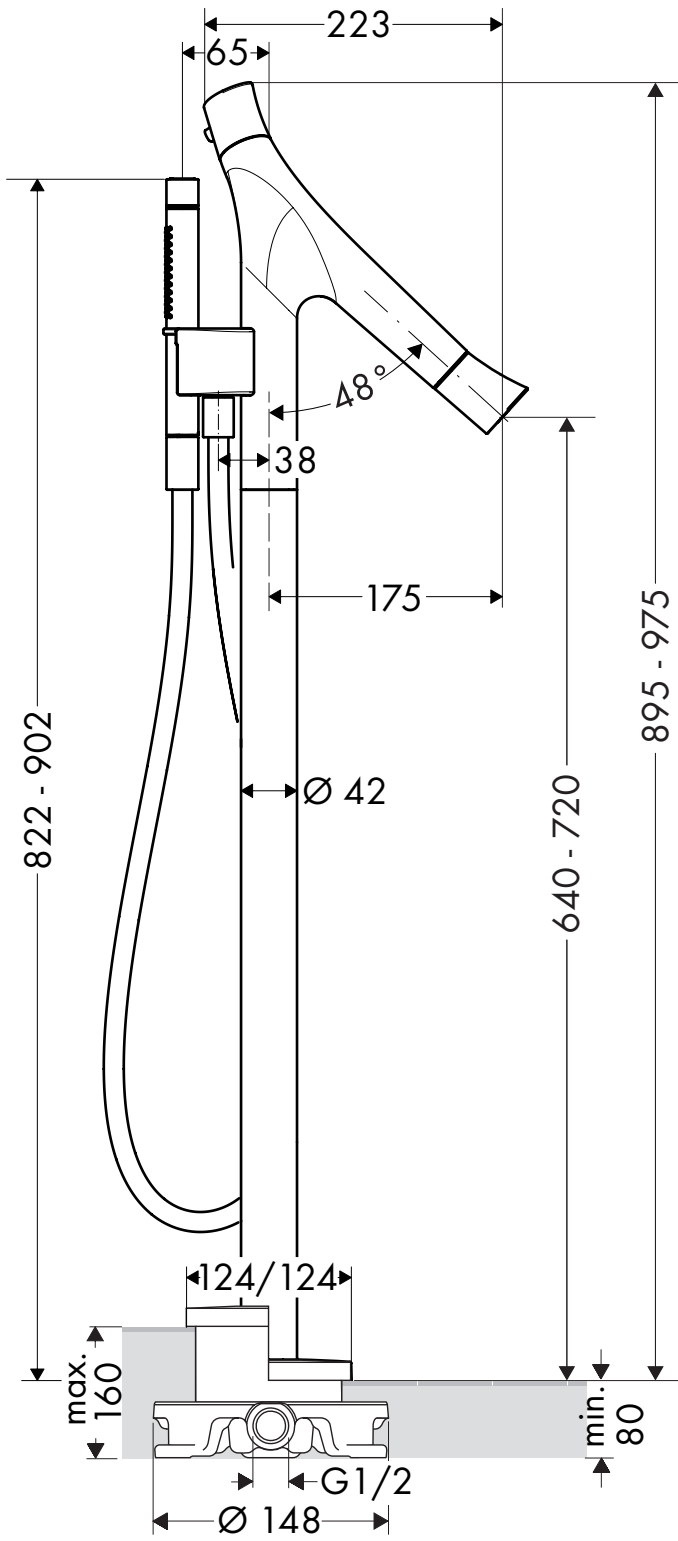

PuraVida

15473000 / 15473400

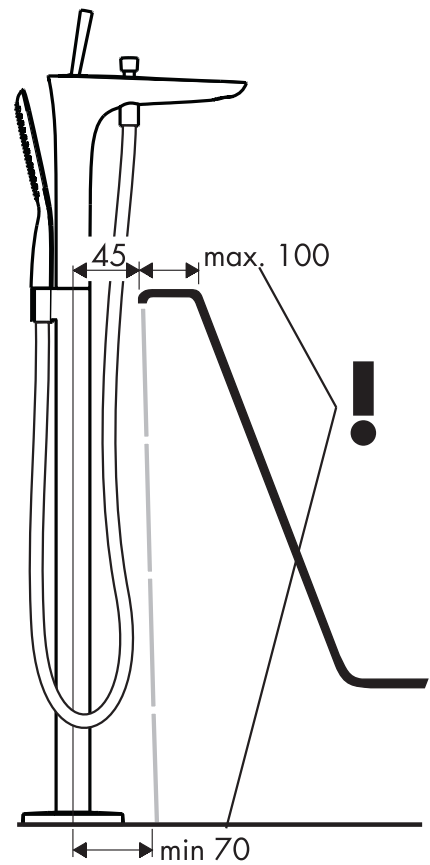
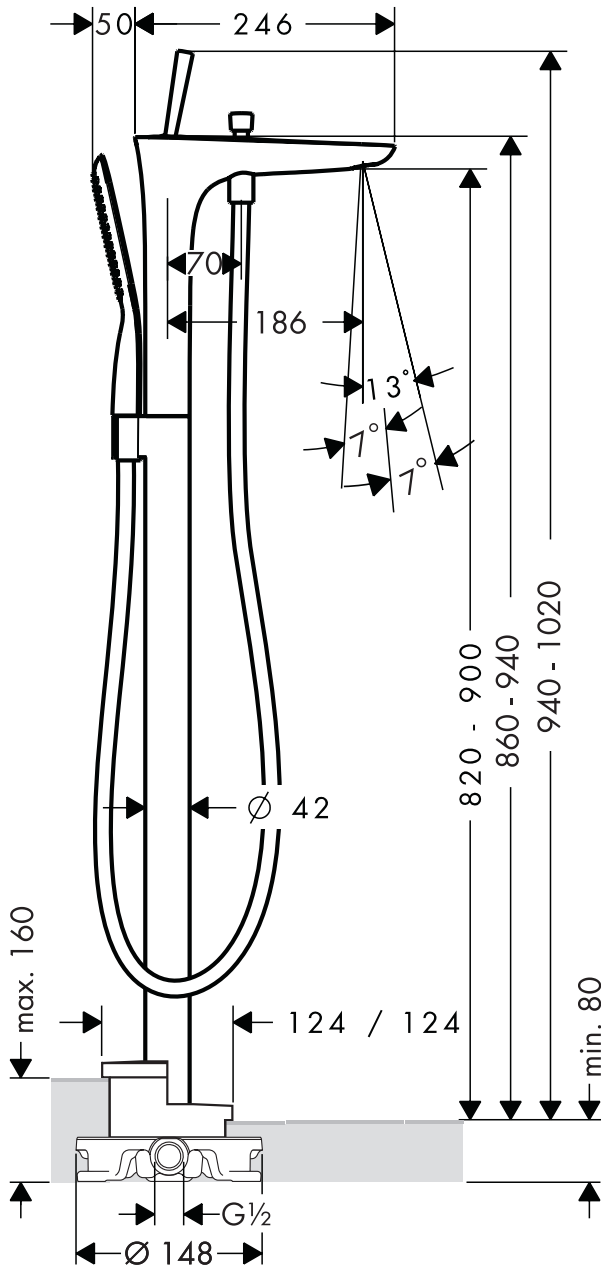



Massaud
18450000

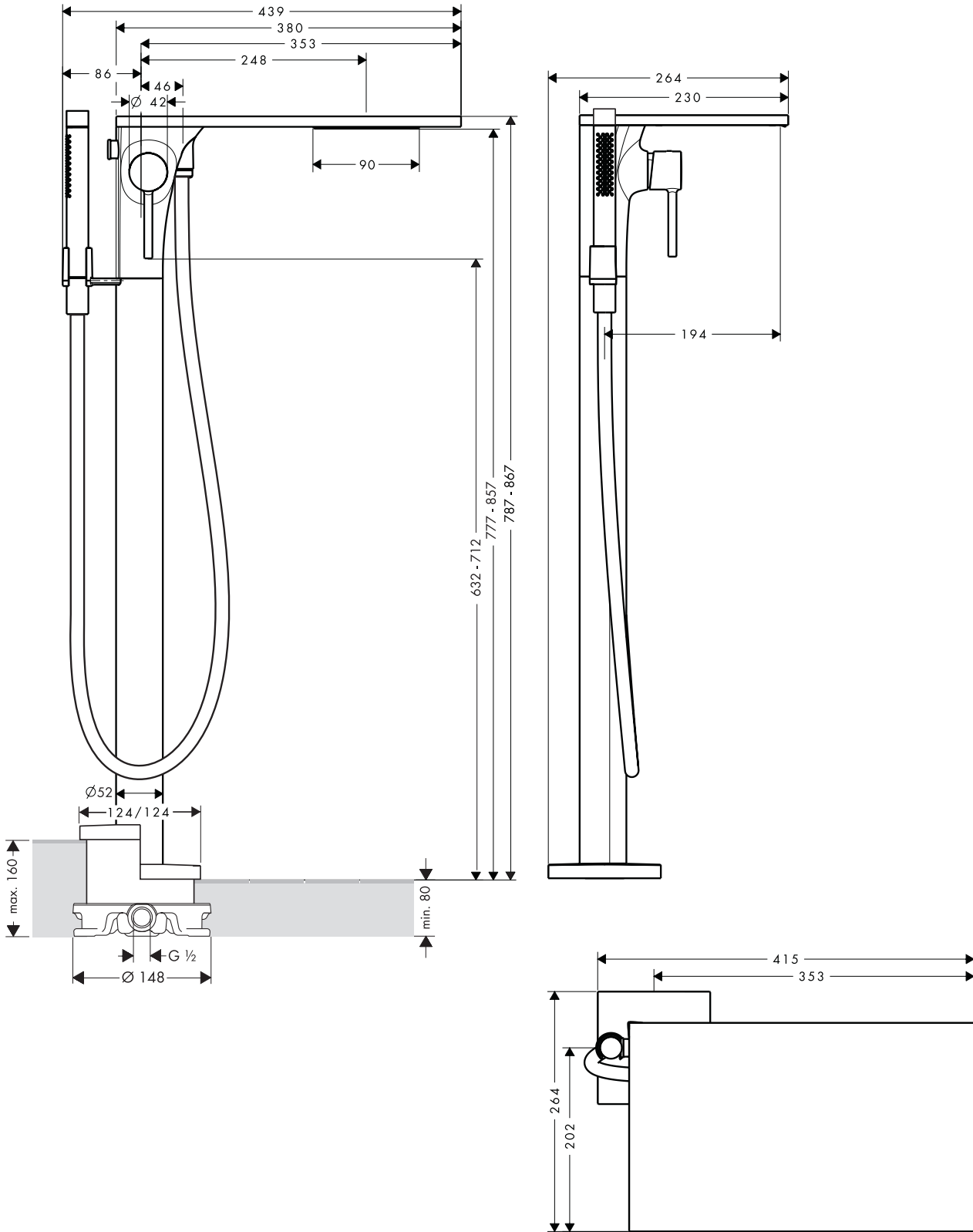



Massaud
18450000

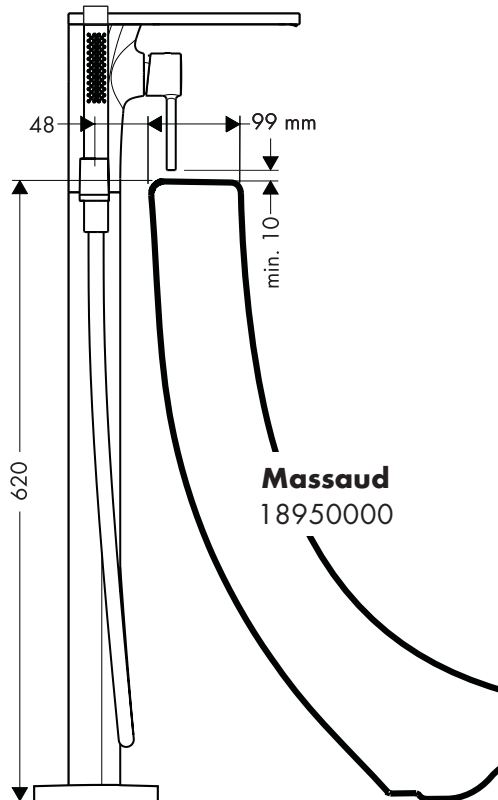
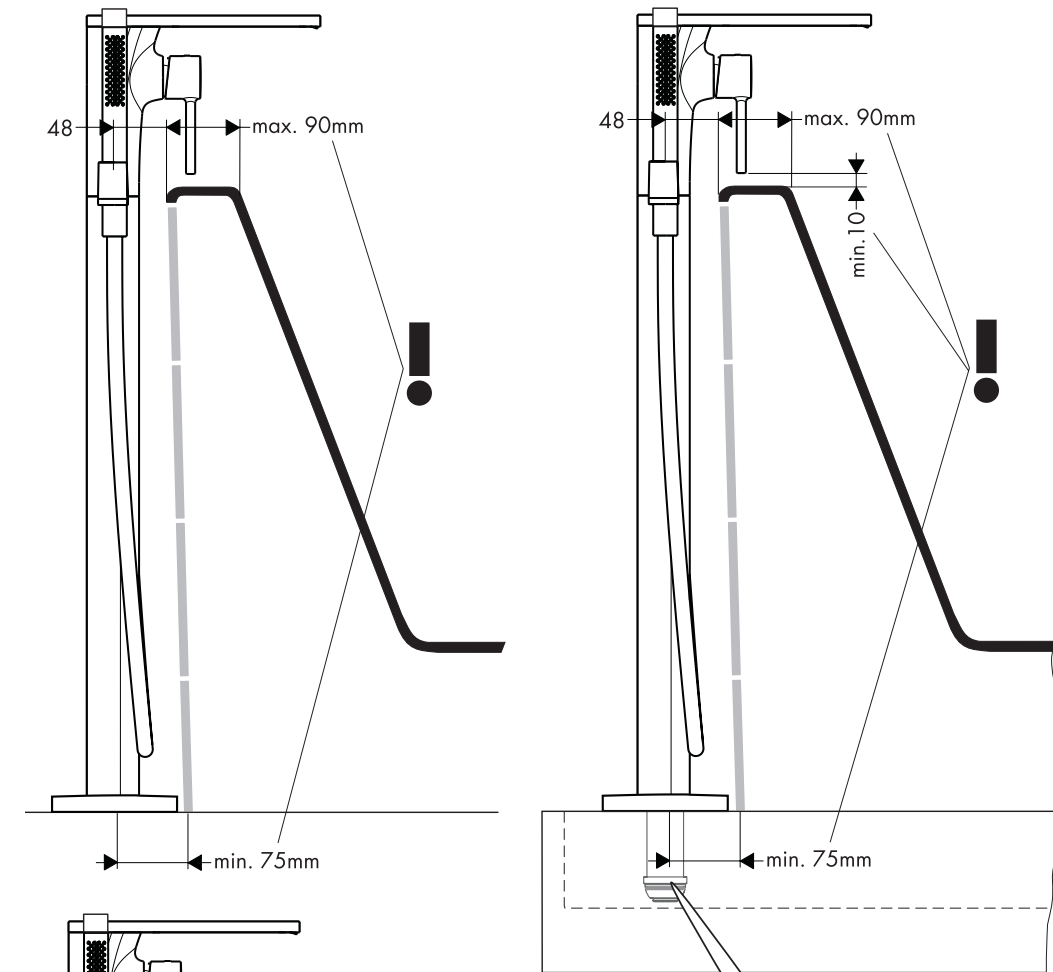

97686000

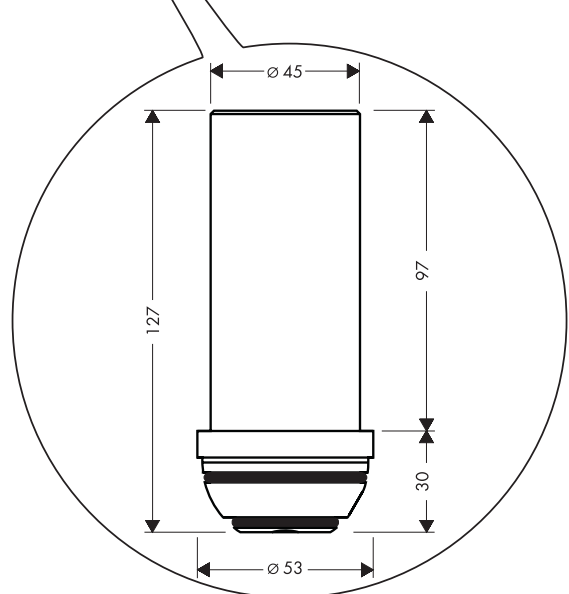



Montreux
16547XXX

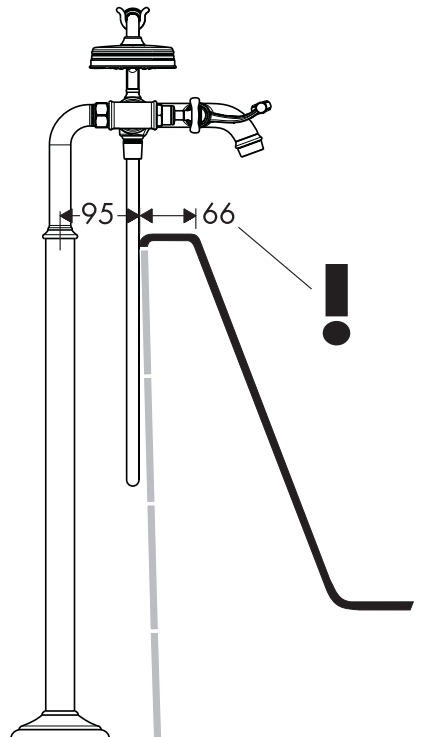
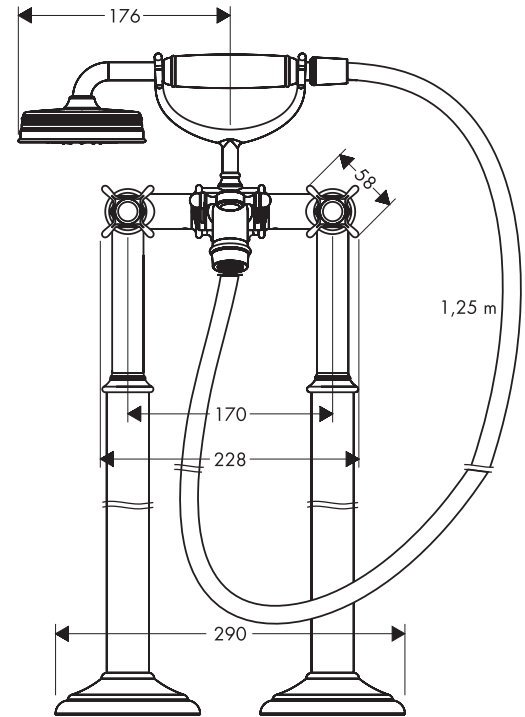
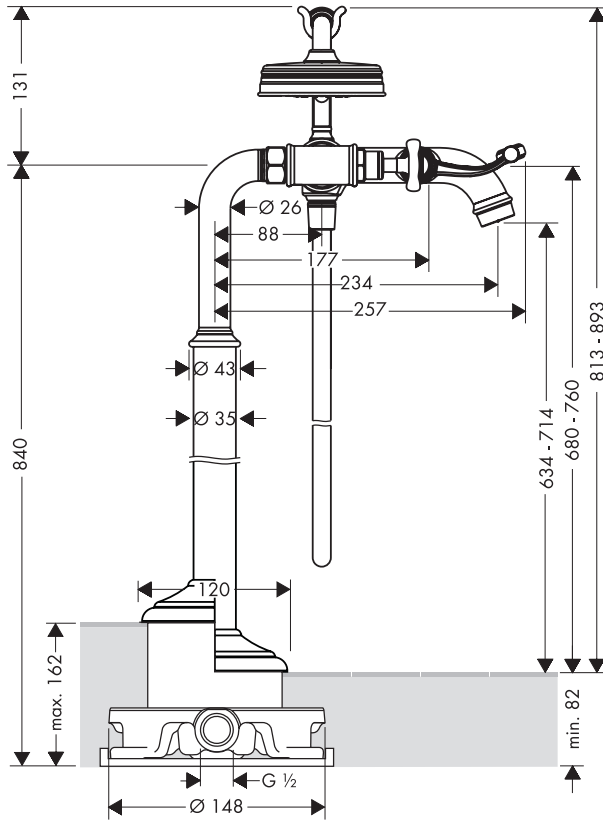



Metris

31471000

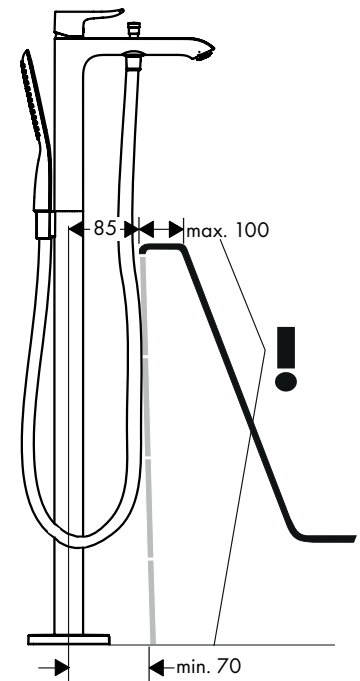
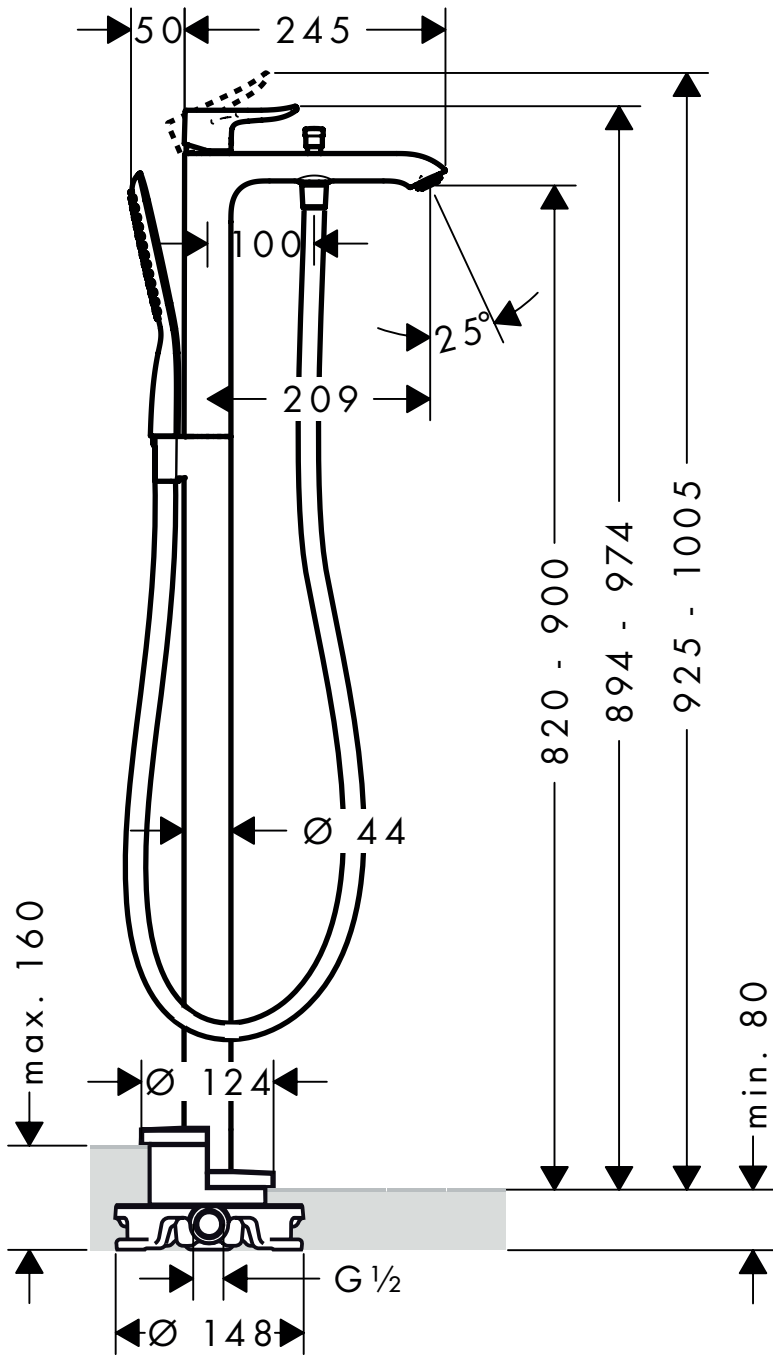



Citterio E

36416000

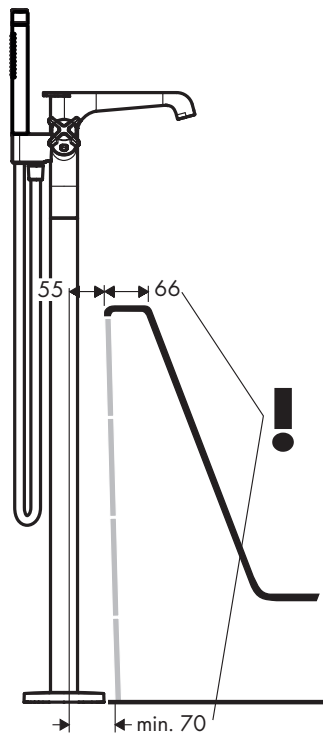
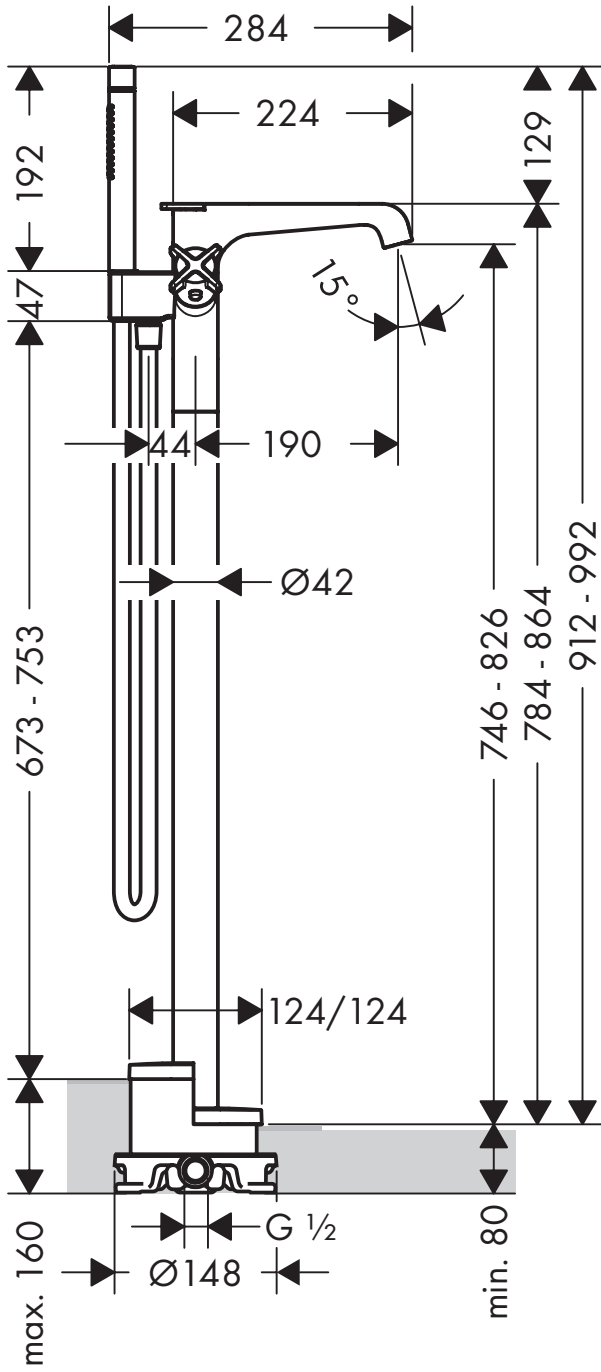

Citterio
39451000

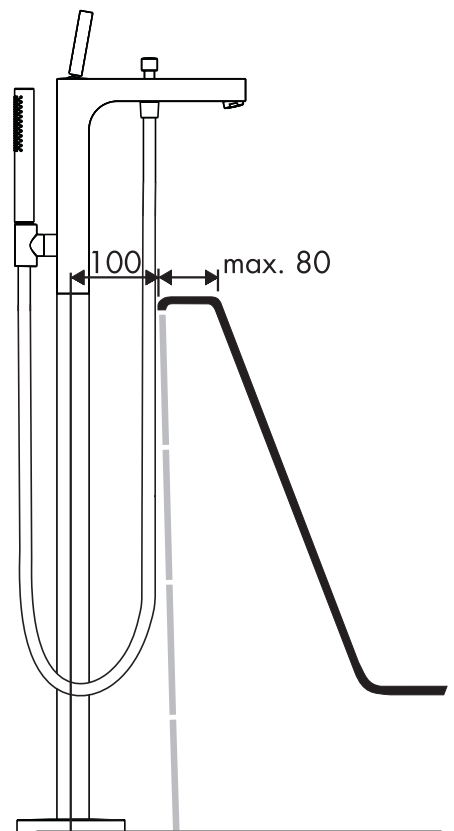
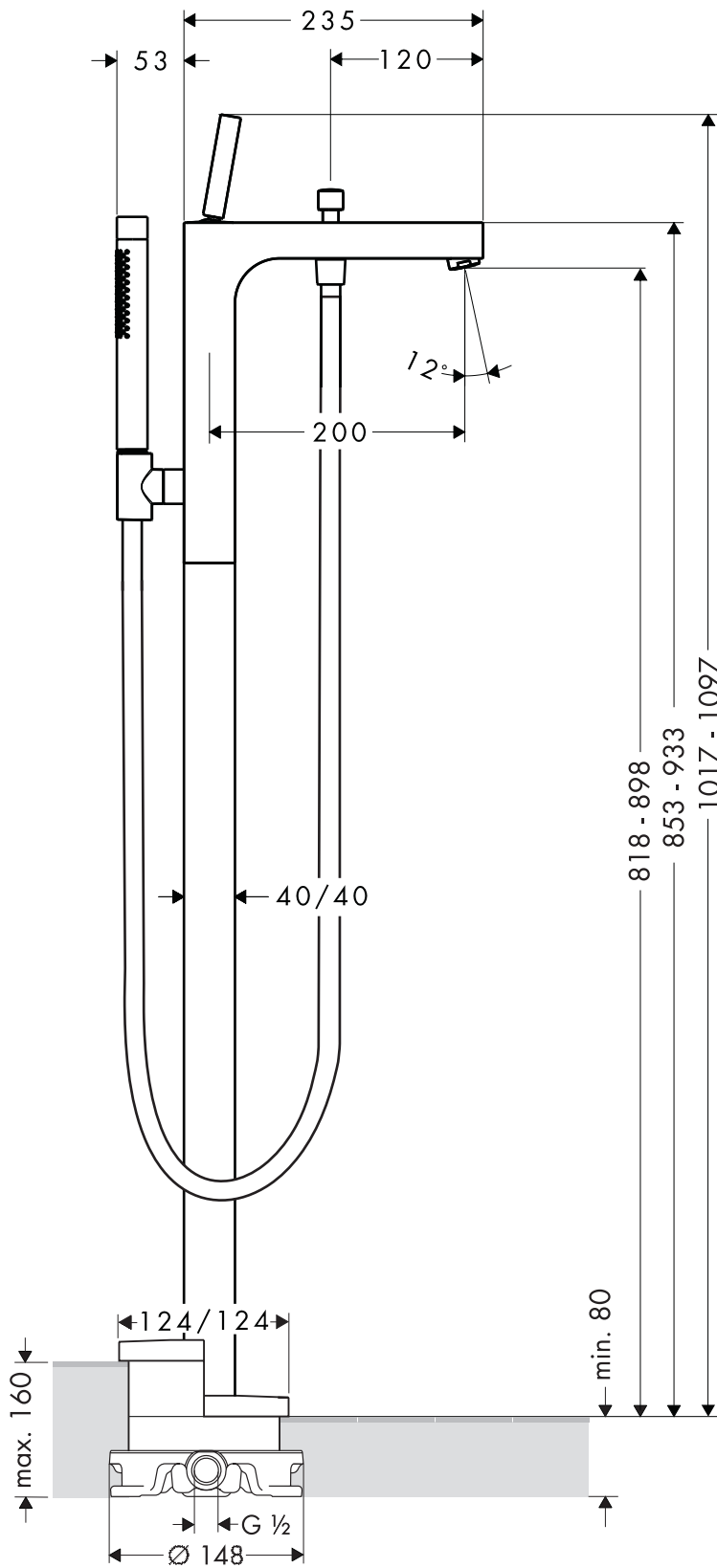



Talis S

72412000

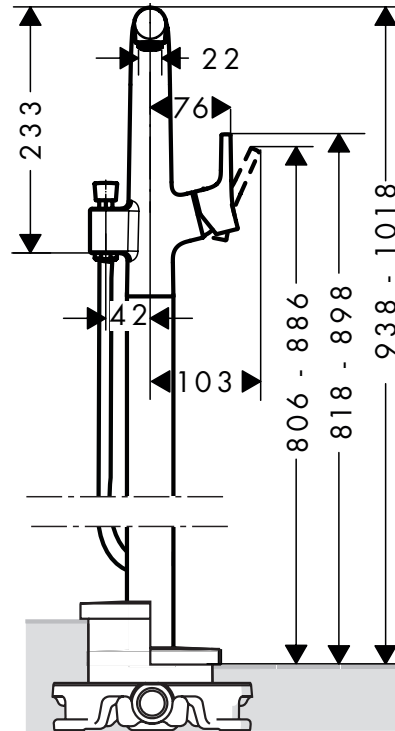
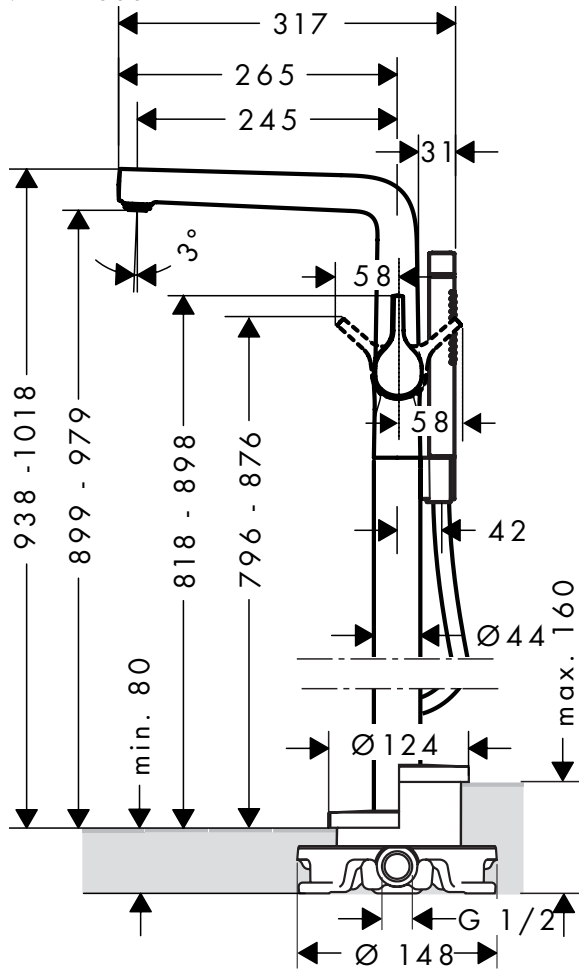



10452180

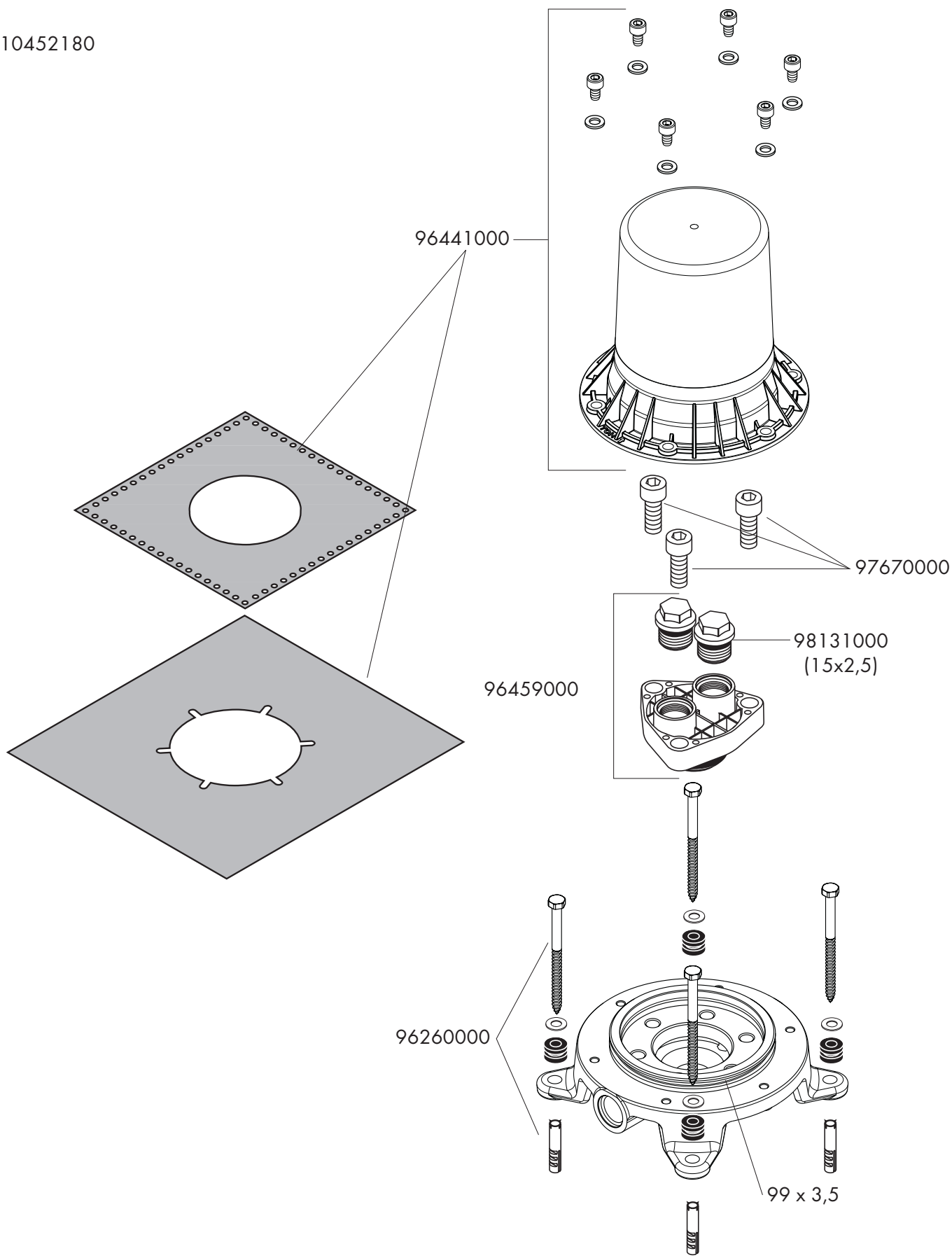



Montreux
16549180

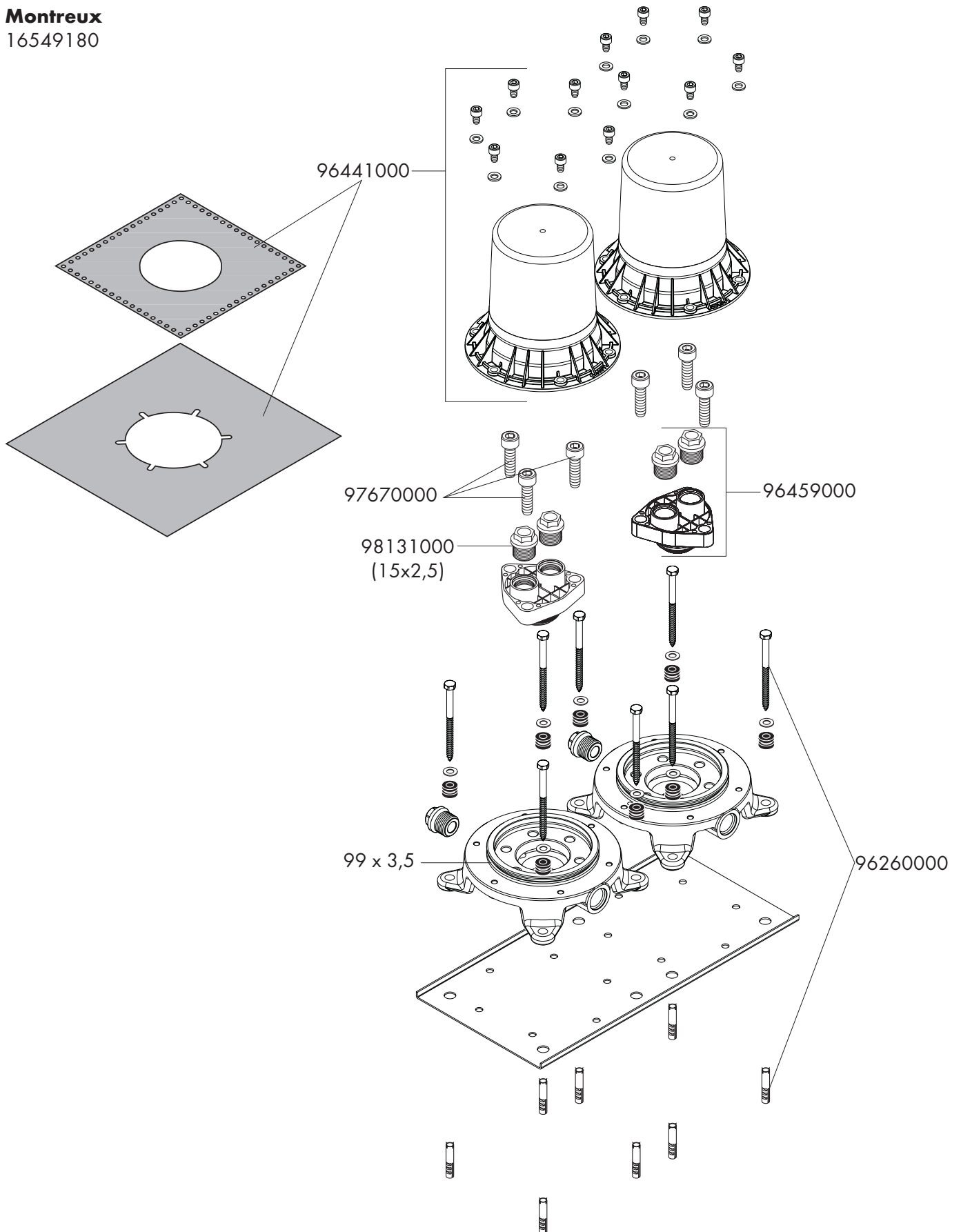

hansgrohe

Hansgrohe · Austraße 5 · 9 · D-77761 Schiltach · Telefon +49 (0) 78 36/51-1282 · Telefax +49 (0) 7836/511440
E-Mail: info@hansgrohe.com · Internet: www.hansgrohe.com

06/2016
9.08641.07