

DE	Gebrauchsanleitung / Montageanleitung	2
FR	Mode d'emploi / Instructions de montage	4
EN	Instructions for use / assembly instructions	6
IT	Istruzioni per l'uso / Istruzioni per Installazione	8
ES	Modo de empleo / Instrucciones de montaje	10
NL	Gebruiksaanwijzing / Handleiding	12
DK	Brugsanvisning / Monteringsvejledning	14
PT	Instruções para uso / Manual de Instalação	16
PL	Instrukcja obsługi / Instrukcja montażu	18
CS	Návod k použití / Montážní návod	20
SK	Návod na použitie / Montážny návod	22
ZH	用户手册 / 组装说明	24
RU	Руководство пользователя / Инструкция по монтажу	26
HU	Használati útmutató / Szerelési útmutató	28
FI	Käyttöohje / Asennusohje	30
SV	Bruksanvisning / Monteringsanvisning	32
LT	Vartotojo instrukcija / Montavimo instrukcijos	34
HR	Upute za uporabu / Uputstva za instalaciju	36
TR	Kullanım kılavuzu / Montaj kılavuzu	38
RO	Manual de utilizare / Instrucțiuni de montare	40
EL	Οδηγίες χρήσης / Οδηγία συναρμολόγησης	42
SL	Navodilo za uporabo / Navodila za montažo	44
ET	Kasutusjuhend / Paigaldusjuhend	46
LV	Lietošanas pamācība / Montāžas instrukcija	48
SR	Uputstvo za upotrebu / Uputstvo za montažu	50
NO	Bruksanvisning / Montasjeveiledning	52
BG	Инструкция за употреба / Инструкция за употреба	54
SQ	Udhëzuesi i përdorimit / Udhëzime rreth montimit	56
AR	دليل الاستخدام / تعليمات التجميع	58

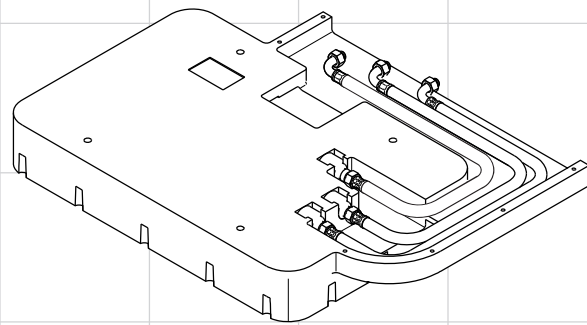

Rainmaker
28414180

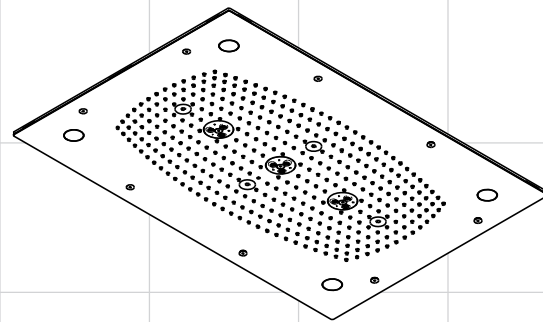

Rainmaker
28417000 / 28418000





Veiligheidsinstructies

- Het douchesysteem mag alleen voor het wassen, hygiënische doeleinden en voor de lichaamreiniging worden gebruikt.
- Kinderen en volwassenen met lichamelijke, geestelijke en/of sensorische beperkingen mogen het douchesysteem niet zonder toezicht gebruiken. Personen onder invloed van alcohol of drugs mogen het douchesysteem niet gebruiken.
- Het contact van de douchestraal met gevoelige lichaamsdelen (bijv. ogen) moet worden voorkomen. Er moet voldoende afstand tussen douche en lichaam aangehouden worden.
- Grote drukverschillen tussen de kouden warm wateraansluitingen dienen vermeden te worden.



Elektrische aansluiting

- De elektrische aansluiting mag alleen door een vakman worden uitgevoerd!
- Stroomvoorziening 230V/N/PE/50Hz (lengte: 0,3 m) vooraf installeren.
- Deze moet middels een 2-polige FI-schakelaar met 30mA afgezekerd worden.



Montage Basisset (zie blz. 68)



Montage Kleurset (zie blz. 73)

- **Attentie!** Leidingen doorspoelen volgens Norm. De mengkraan vervolgens monteren en controleren.
- Bij de montage van het produkt door een vakkundige installateur moet men erop letten dat het bevestigingsoppervlak op één oppervlak zit (dus geen opliggende voegen of verspringende tegels), de wand geschikt is voor montage van produkten en zeker geen zwakke plekken bevat.
- De bijgevoegde schroeven en duvels zijn alleen geschikt voor beton. Bei andere wandsoorten dient u te letten op de voorschriften van de fabrikant van de schroeven en duvels.
- De afvoercapaciteit moet voldoende gedimensioneerd worden.
- De douche alleen installeren na een afsluitbare kraan.

Onderhoudsinstructies

- Keerleppele moeten volgens DIN EN 1717 regelmatig en volgens plaatselijk geldende eisen op het functioneren gecontroleerd worden. (Tenminste een keer per jaar).

Technische gegevens

Stroomdruk voor de kraan:	max. 1 MPa
Aanbevolen werkdruk:	0,3 - 0,5 MPa
(1 MPa = 10 bar = 147 PSI)	
Temperatuur warm water:	max. 60 °C
Aanbevolen warm water temp.:	42 °C
Veiligheidsmechanisme:	38 °C

Waarschuwing: Een overschrijding van die temperatuur kan brandwonden veroorzaken!



Toebehoren (zie blz. 60)



Maten (zie blz. 60)



Montagegereedschap (zie blz. 60)



Montagevoorbeelden

Installatievoorbeelden met massagegevens en capaciteitsdimensioering staan op pagina 62.

Bediening (zie blz. 76)

Reserveonderdelen (zie blz. 76)



Service Verlichting vervangen (zie blz. 77)



Reinigen (zie blz. 78)



Electro-installateur

De installatie- en controlewerkzaamheden moeten uitgevoerd worden door een geautoriseerde electricien die rekening houdt met de normen VDE 0100 Deel 701 en IEC 60364-7-701.

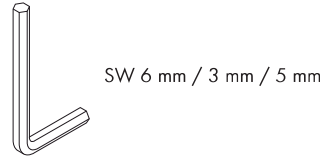
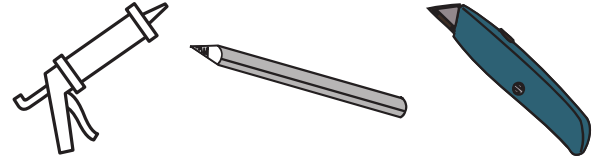
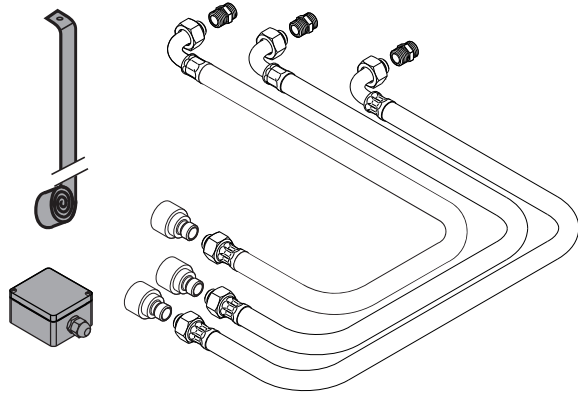
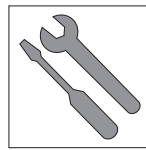
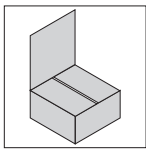

M 8x100

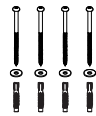

4,5x90



4,5x50

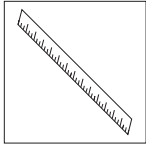

Rainmaker 28414180

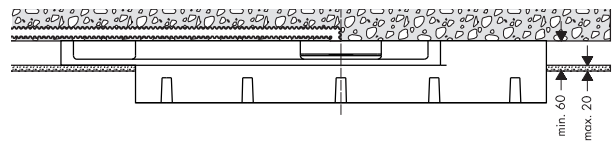
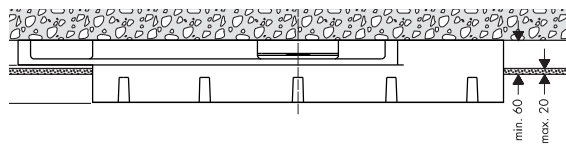
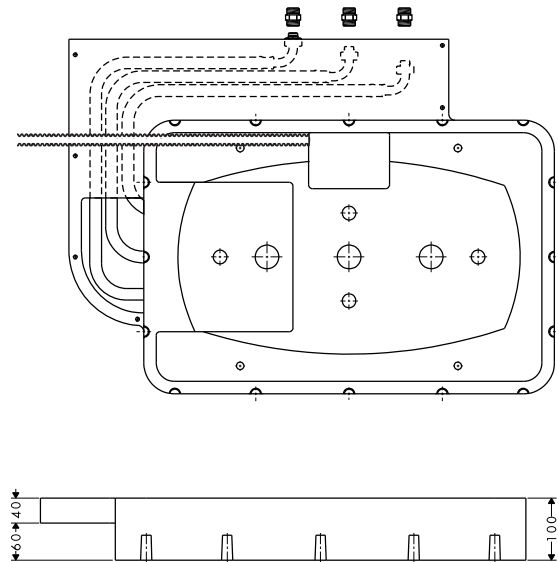
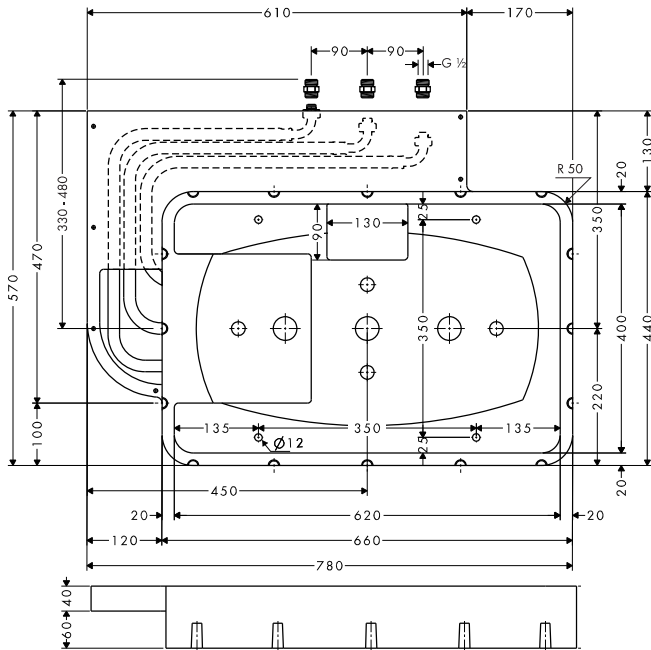

**Rainmaker
28417000 / 28418000**

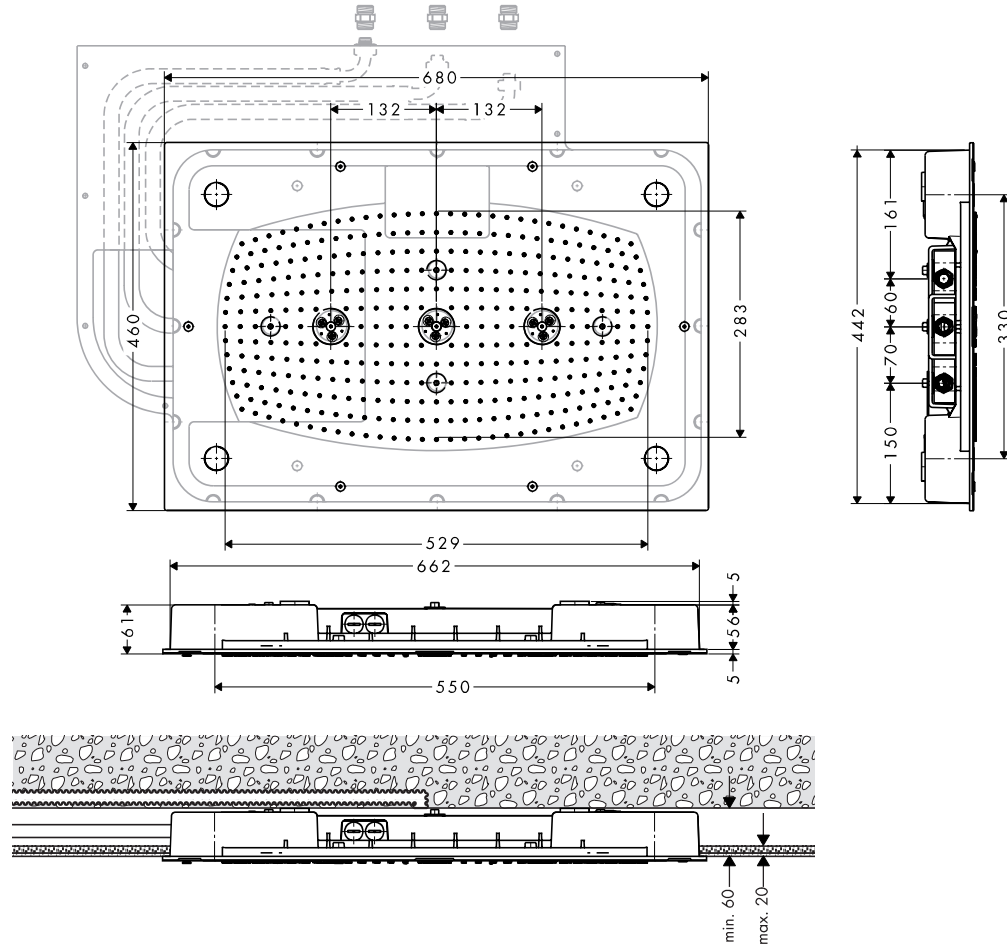
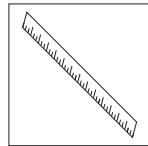

**Rainmaker
28418000**

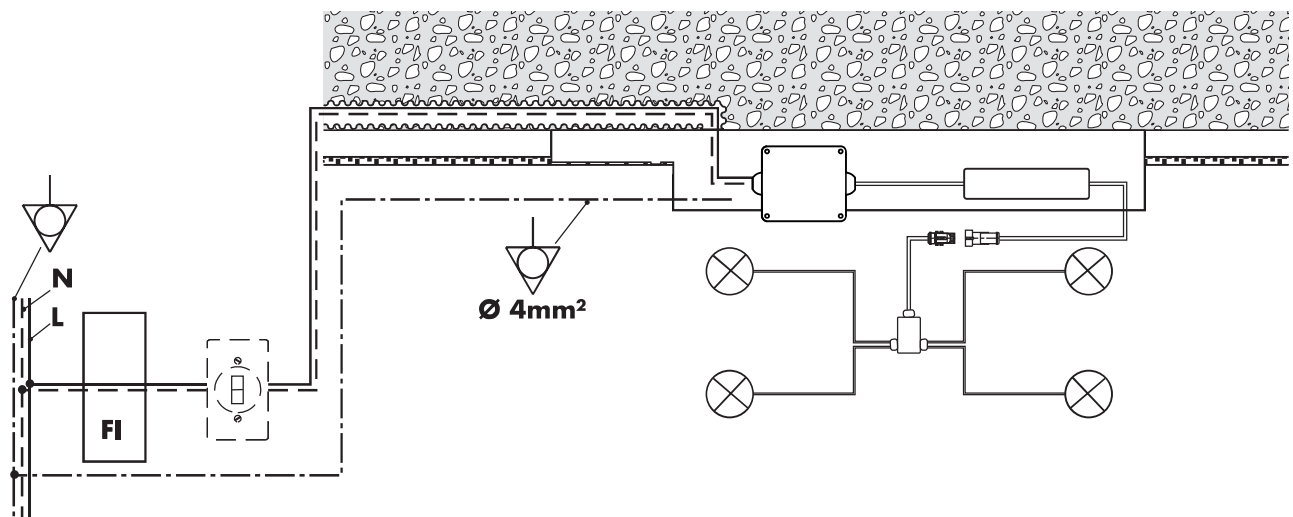

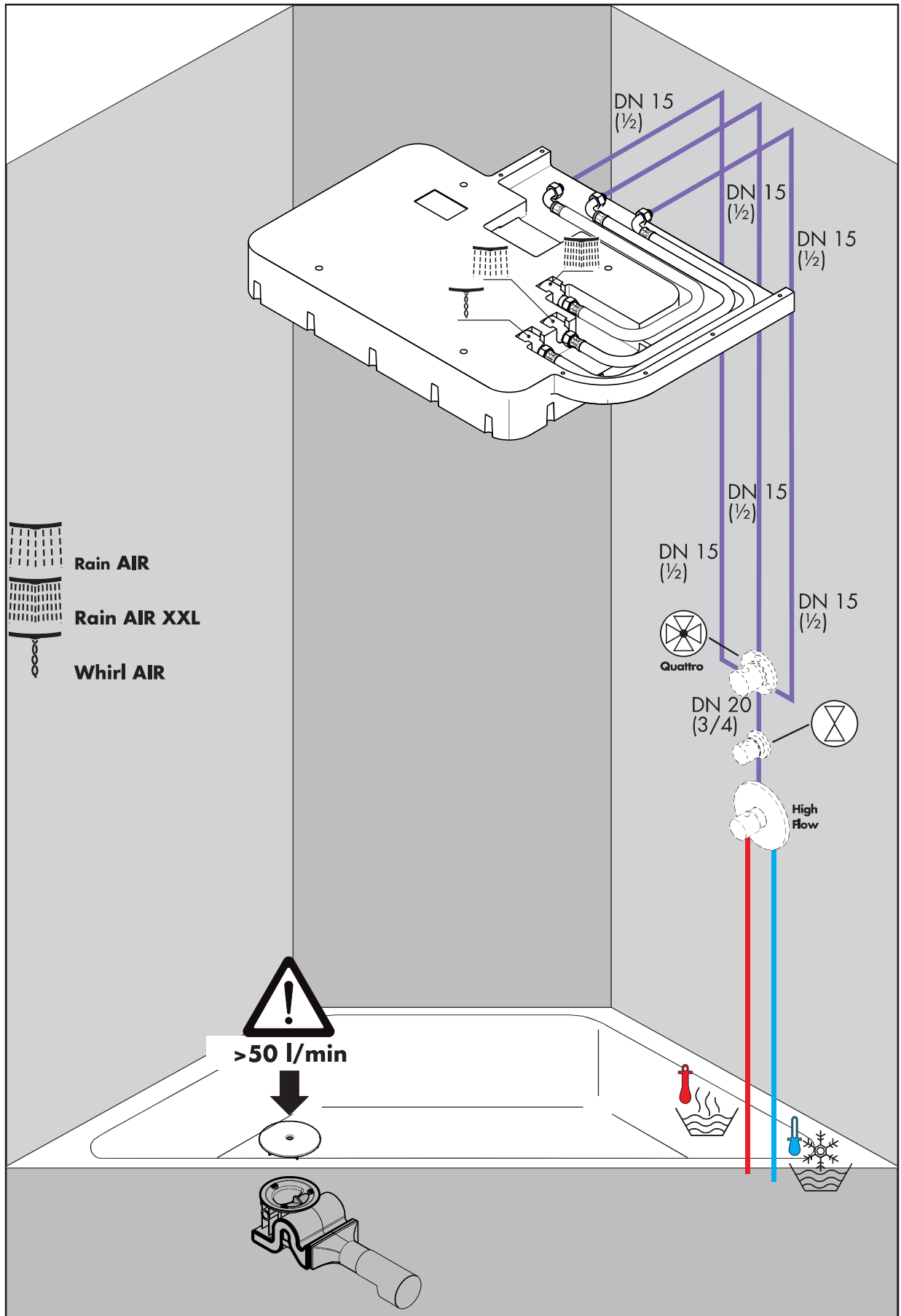

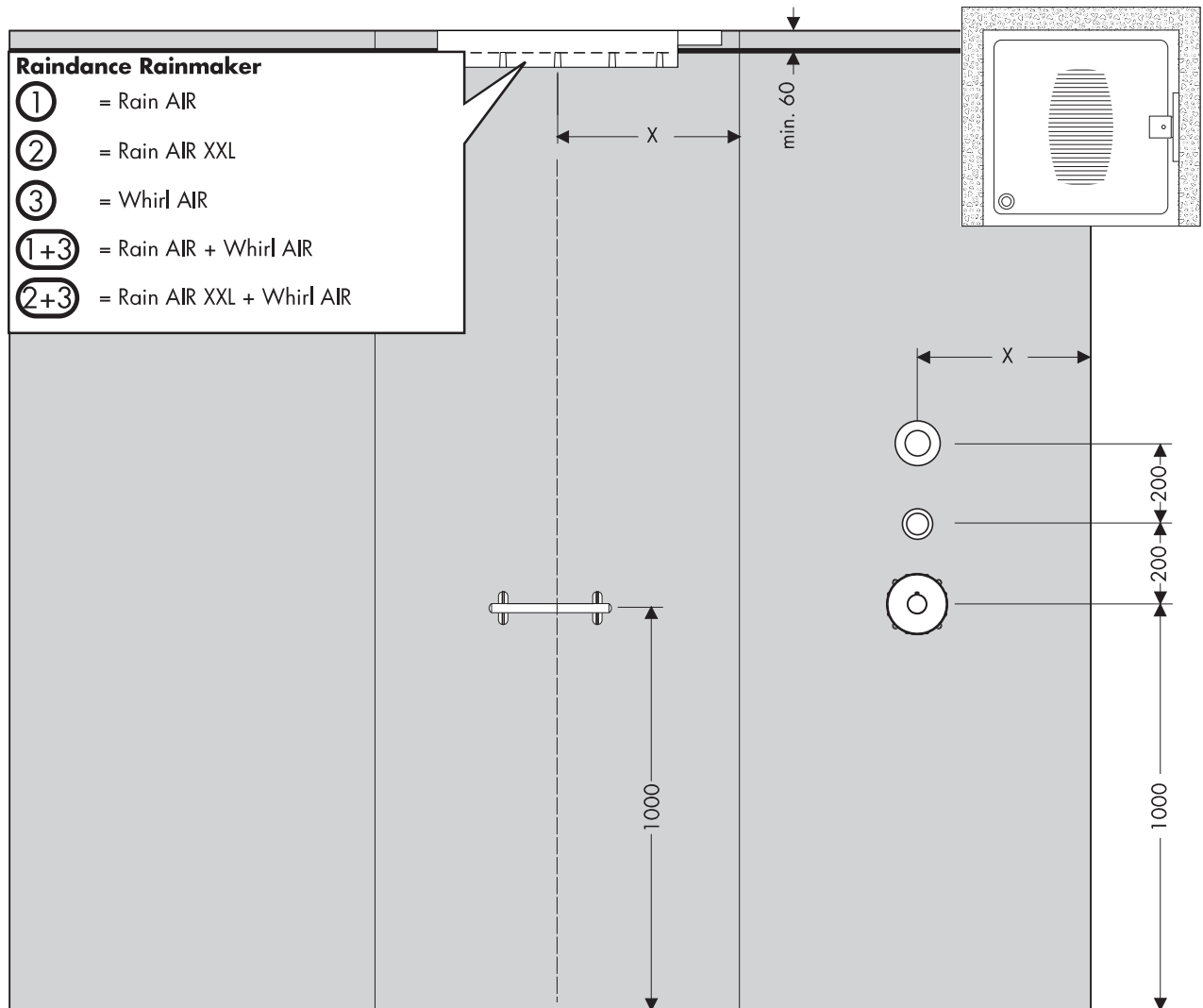
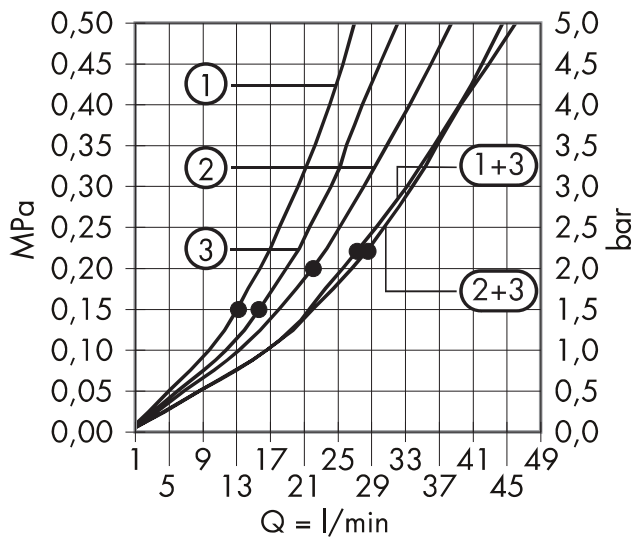

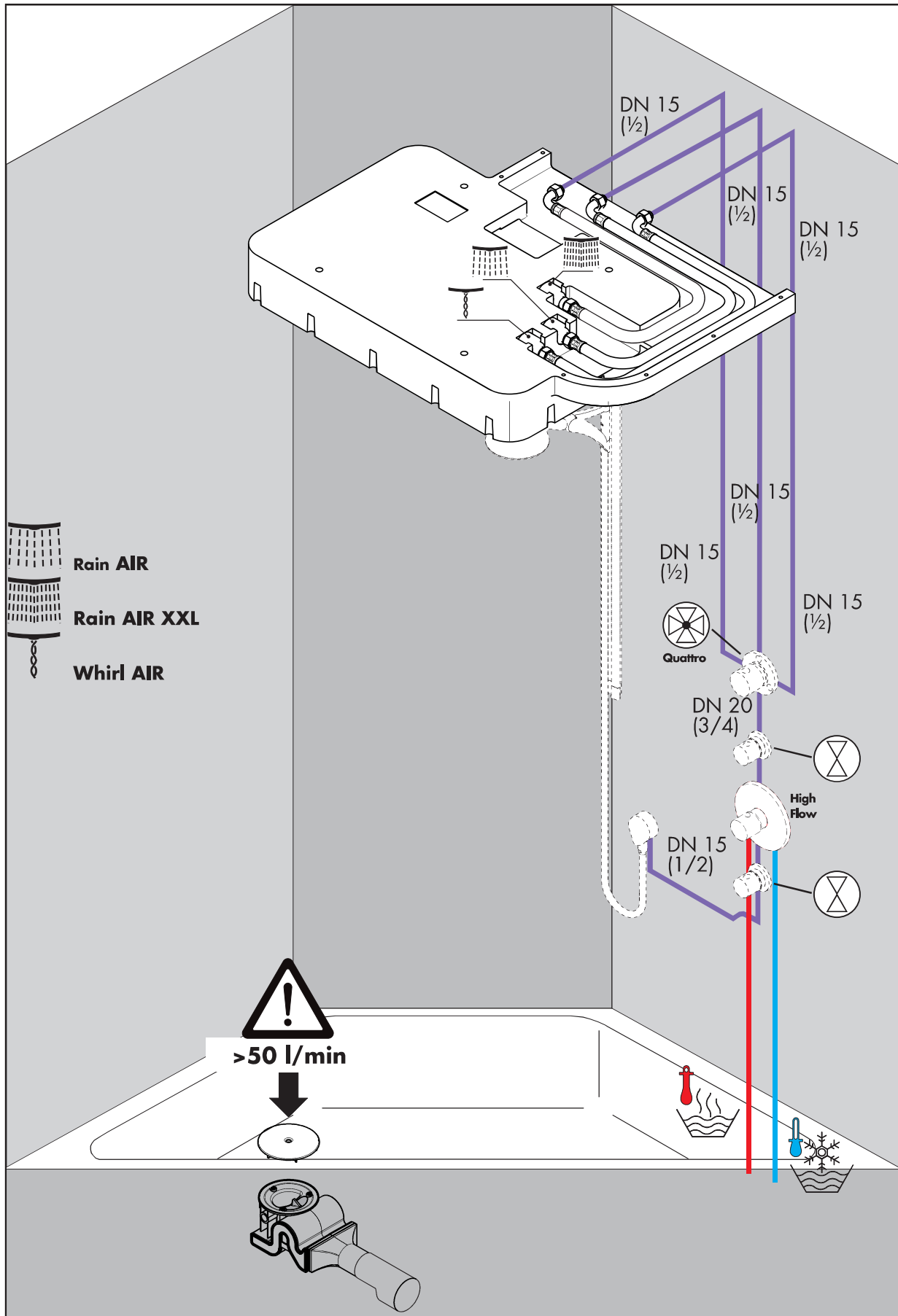

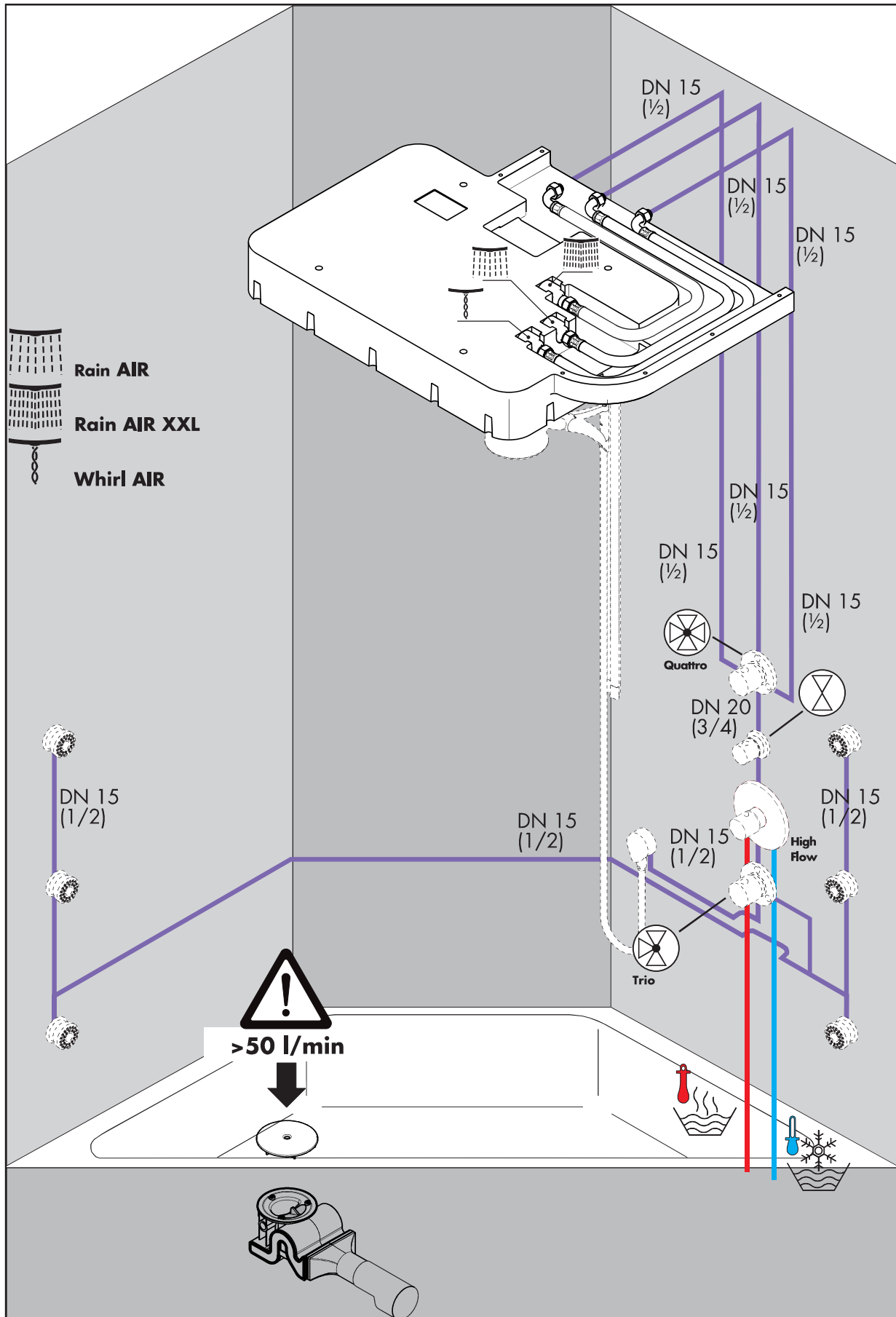

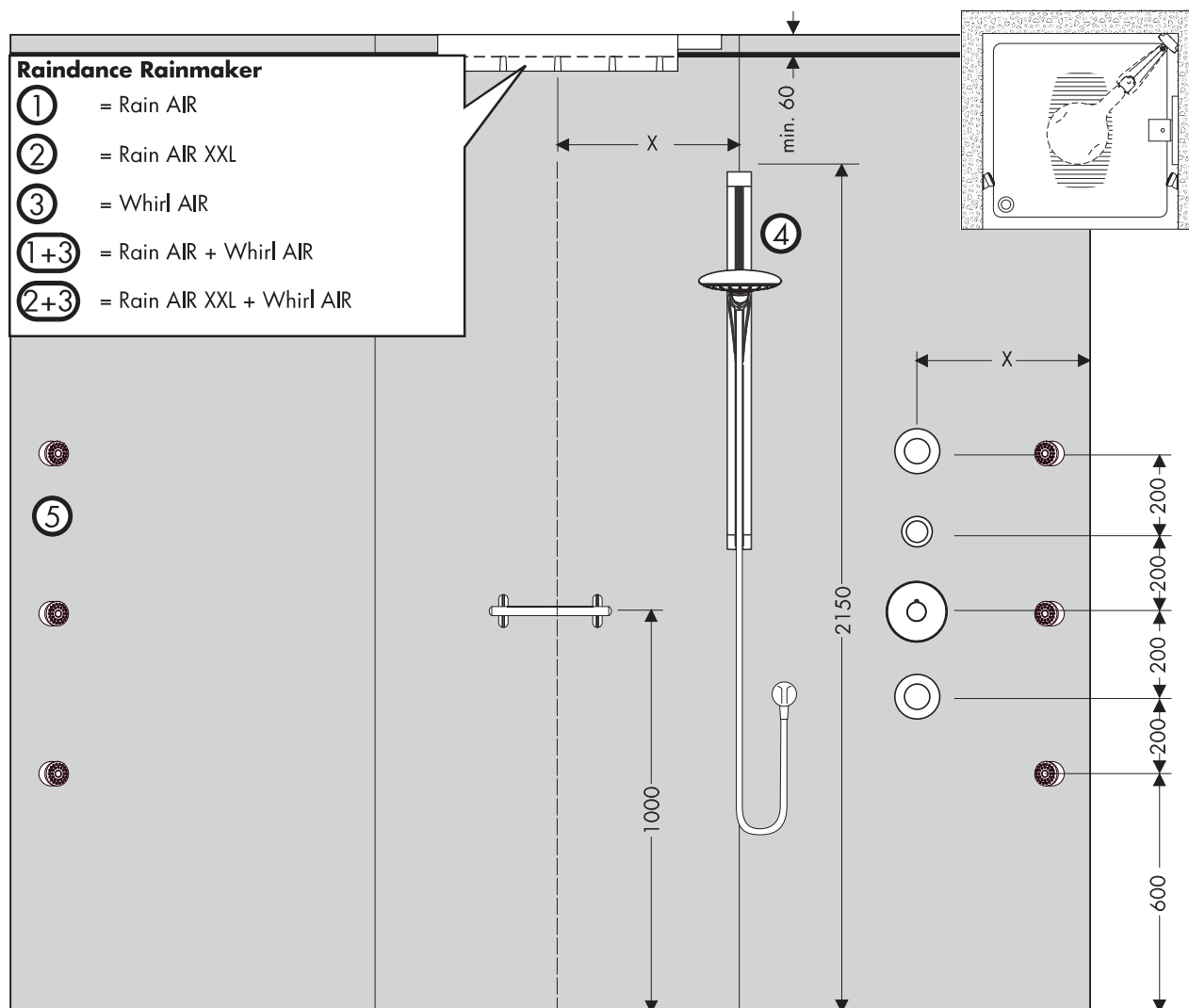
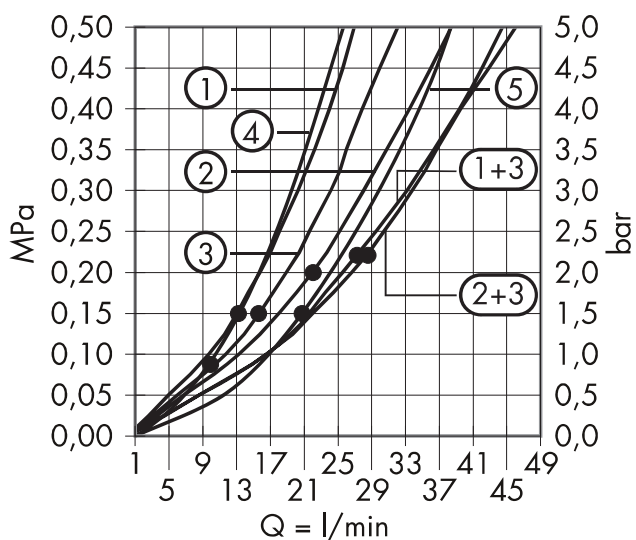

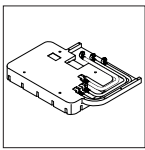

Rainmaker 28414180

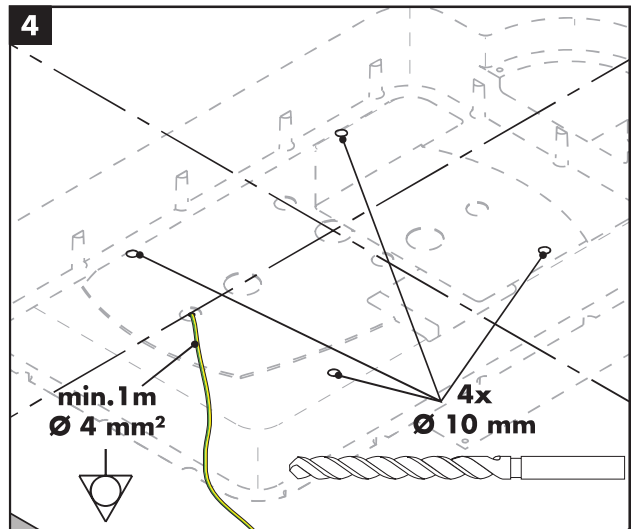
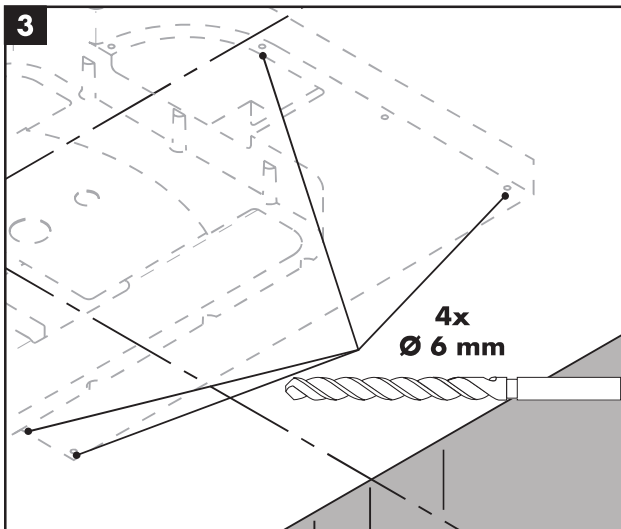
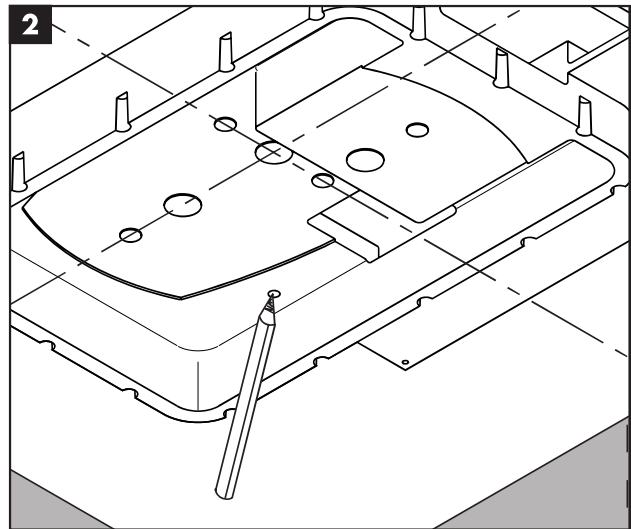
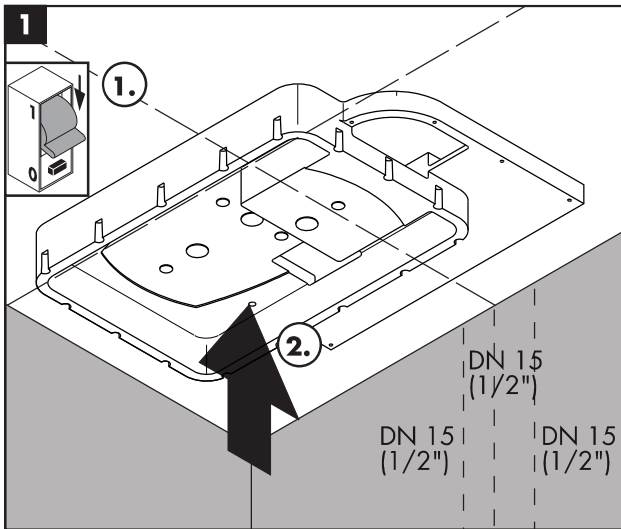
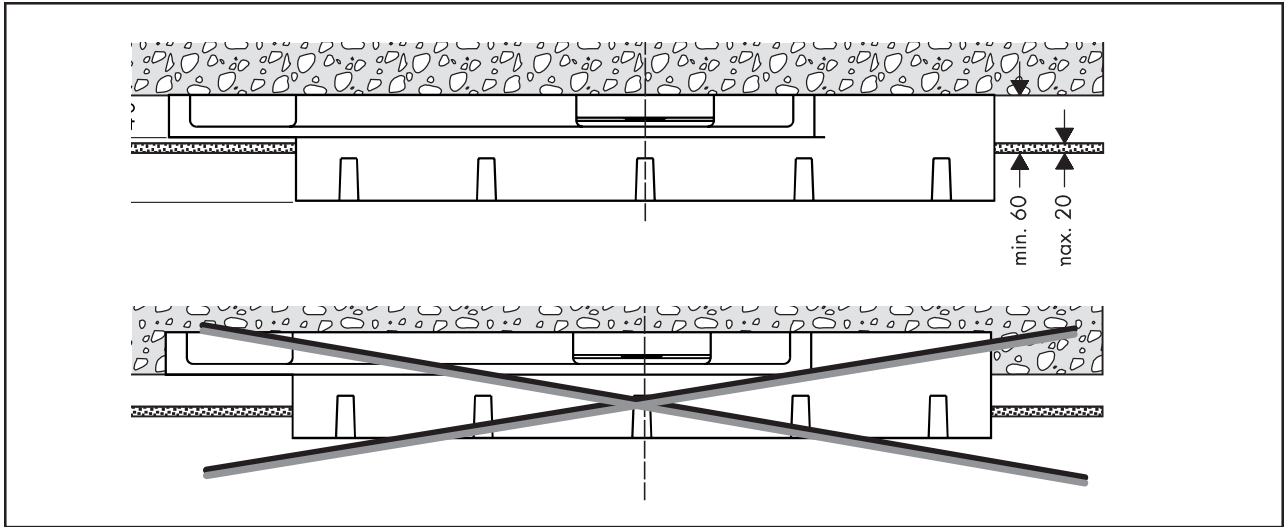

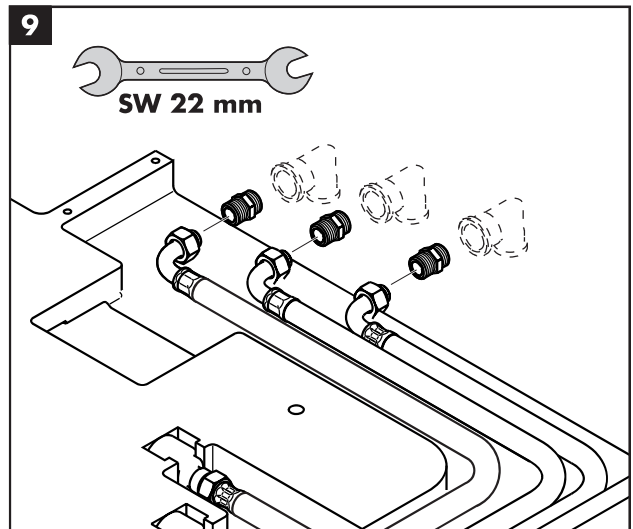
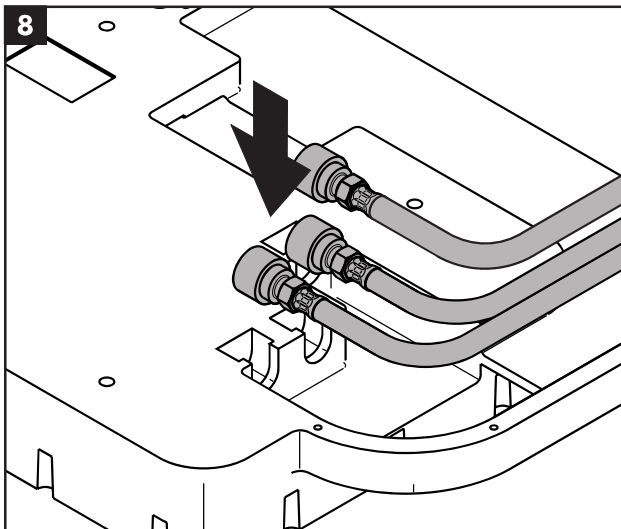
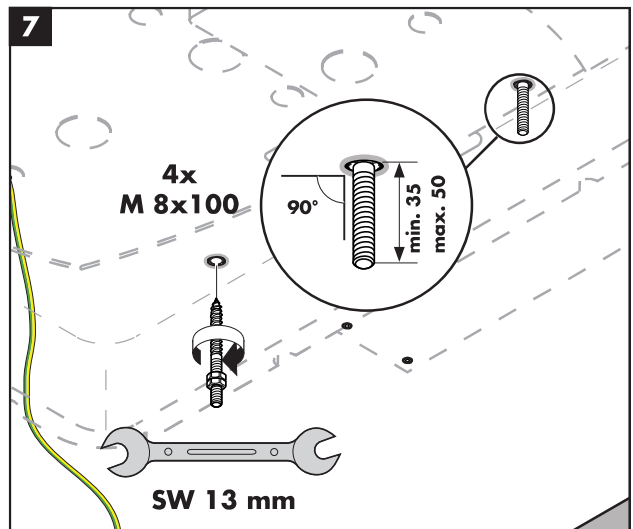
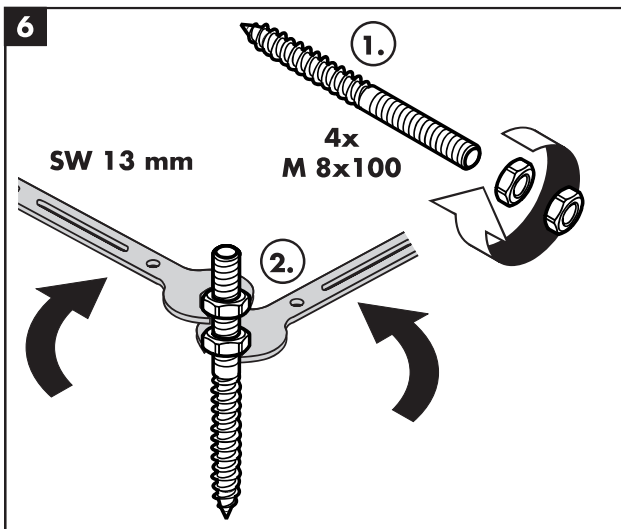
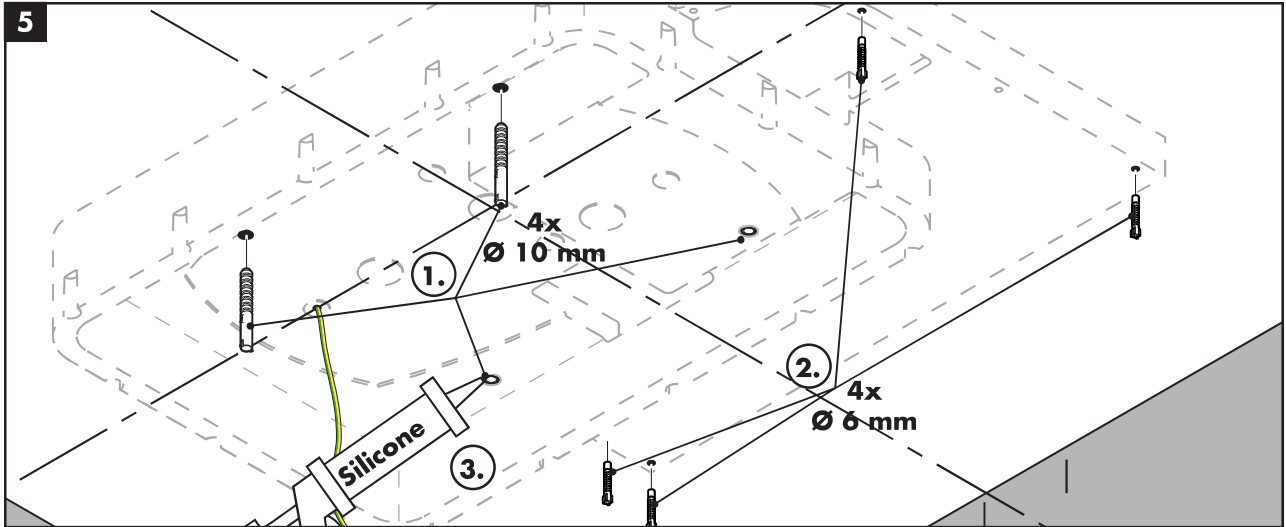
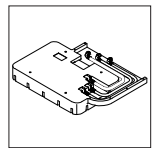

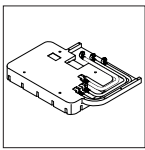

Rainmaker
28414180

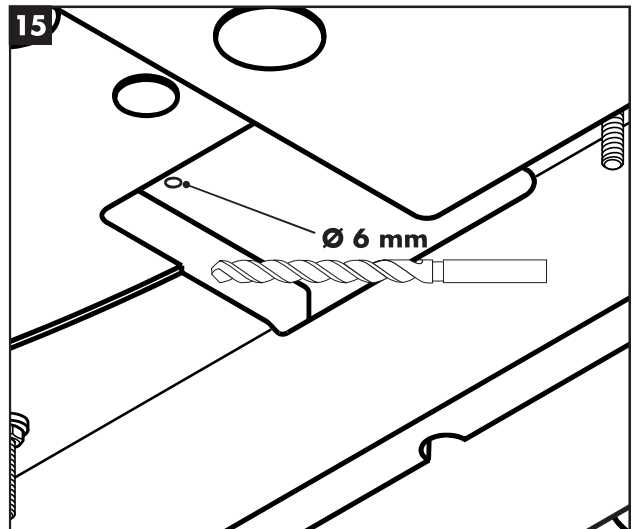
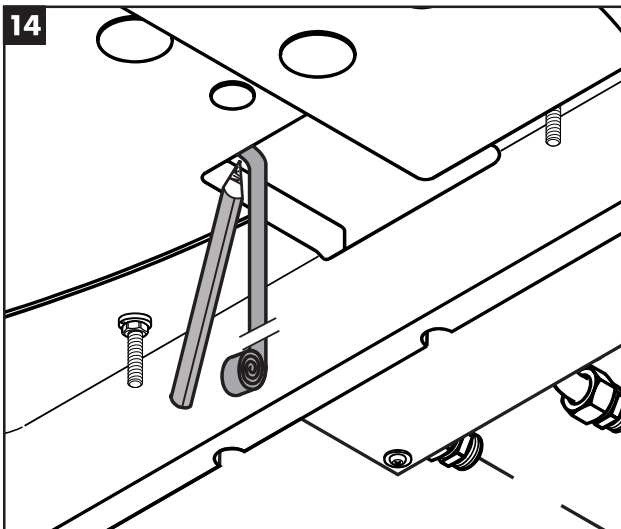
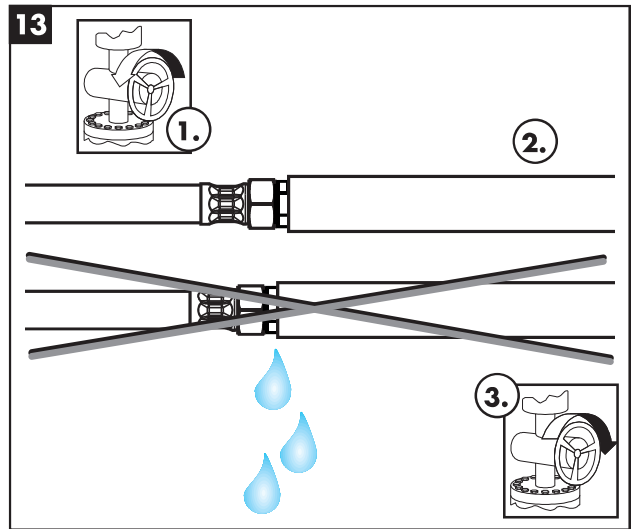
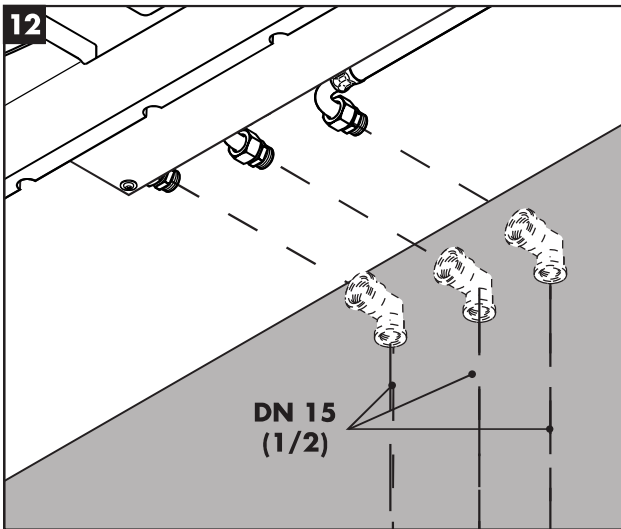
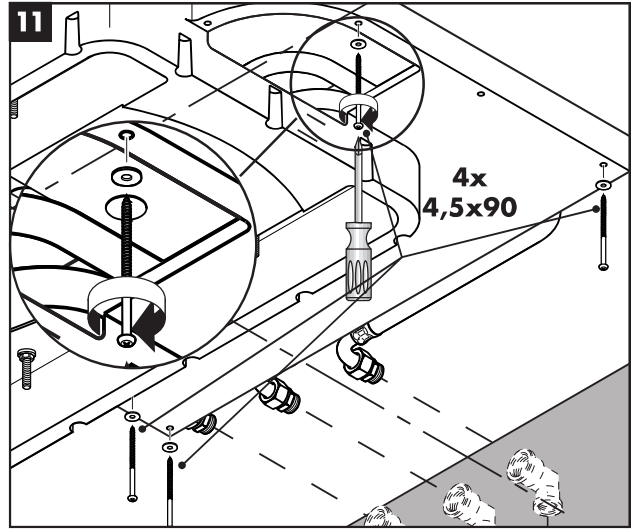
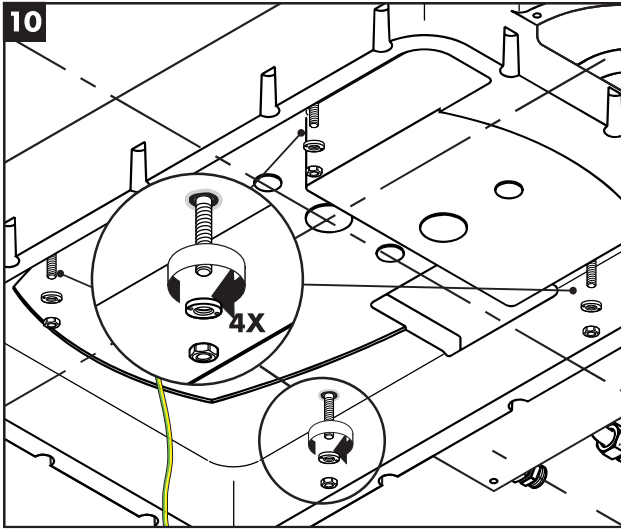

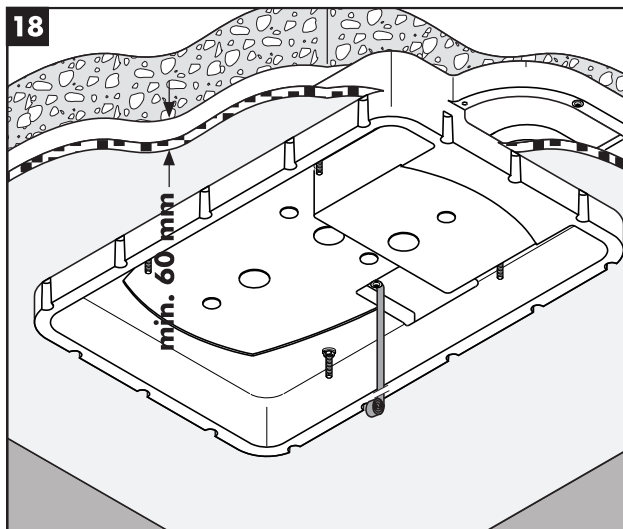
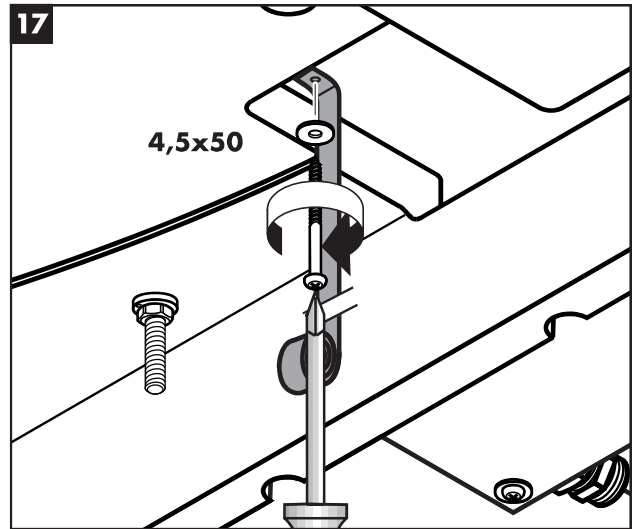
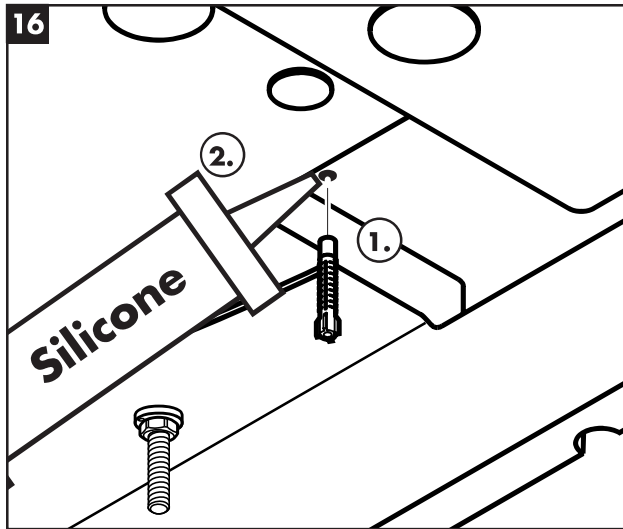
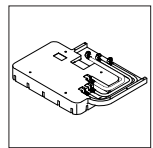

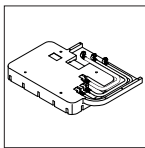

Rainmaker
28414180 / 28418000

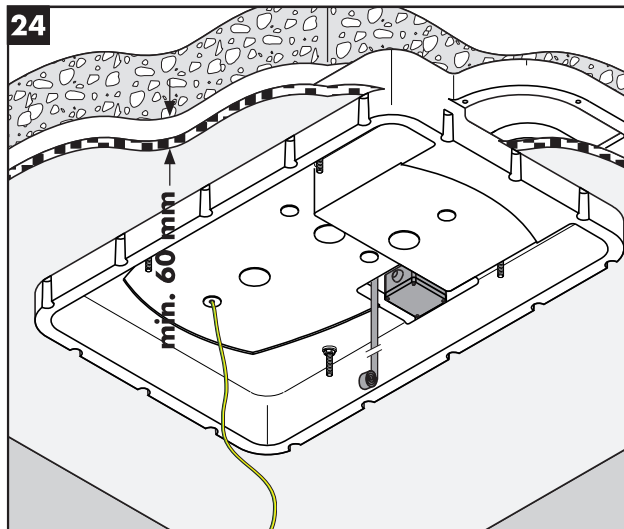
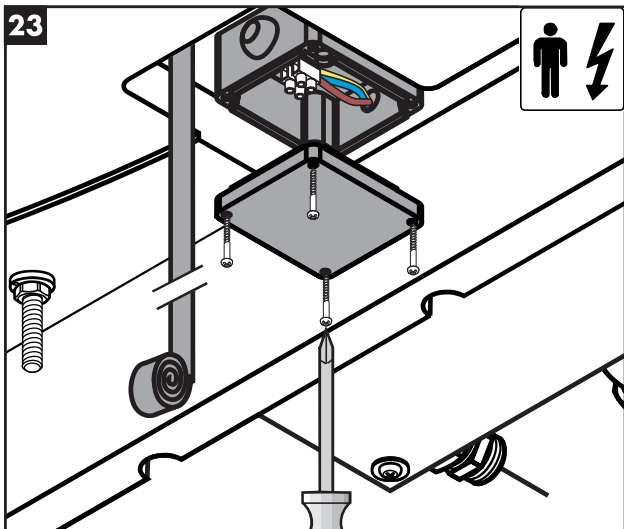
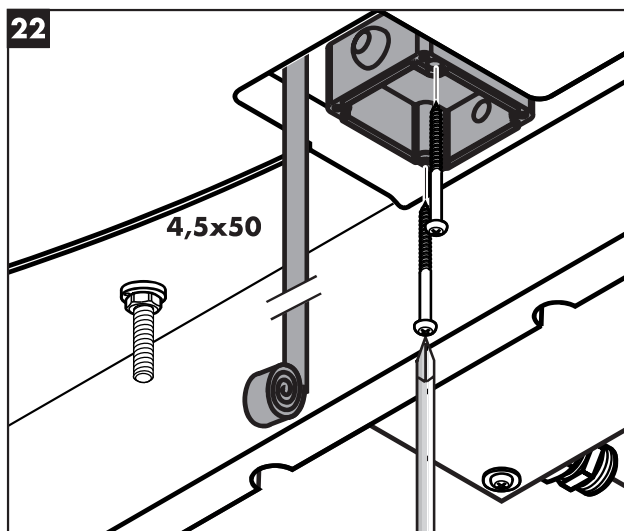
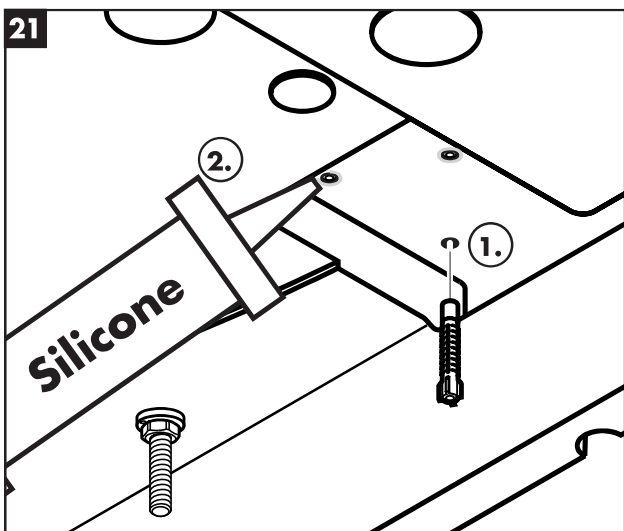
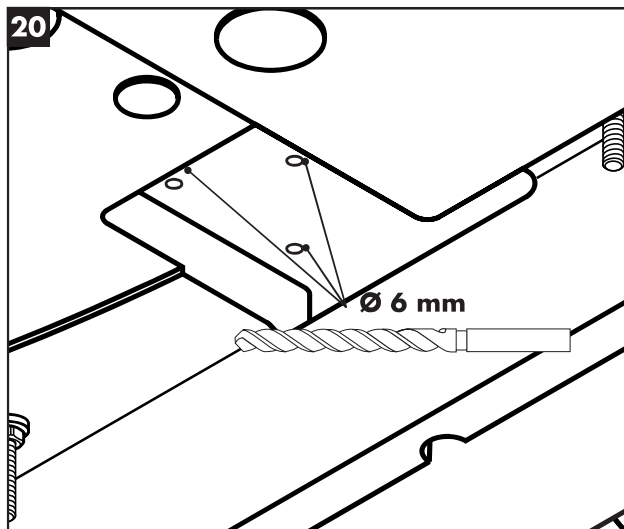
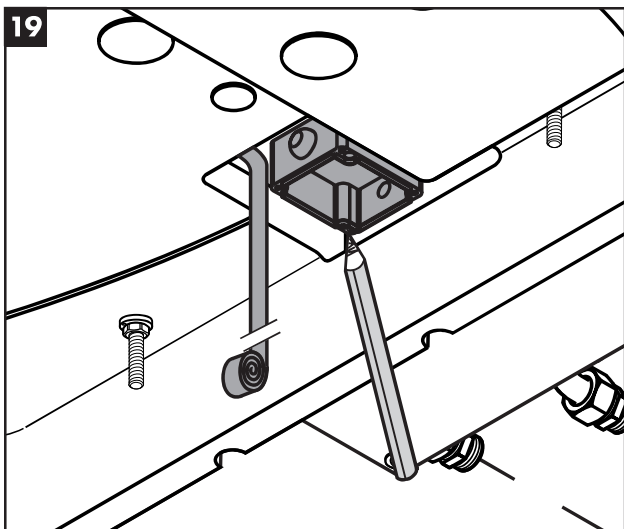

Rainmaker
28417000 / 28418000

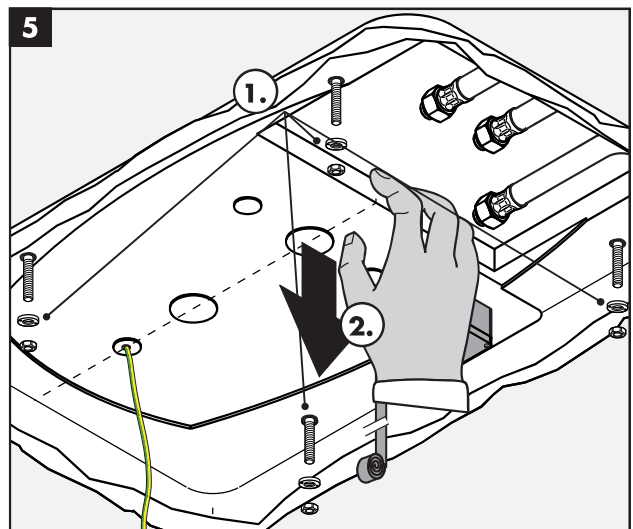
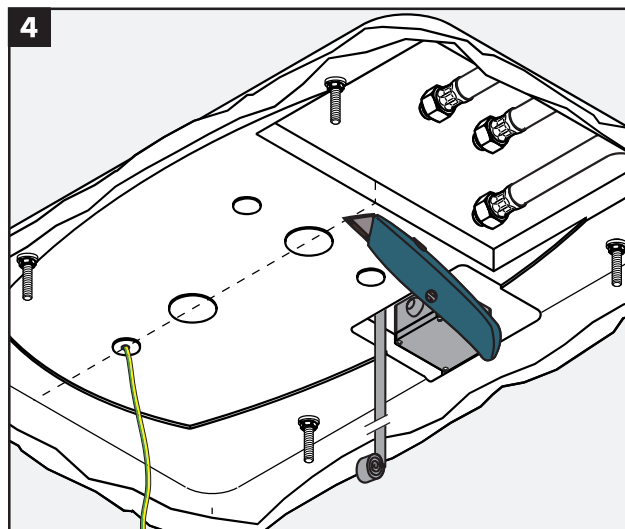
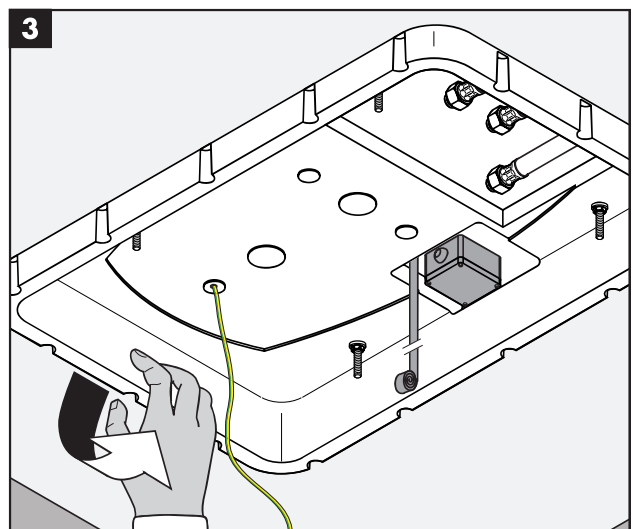
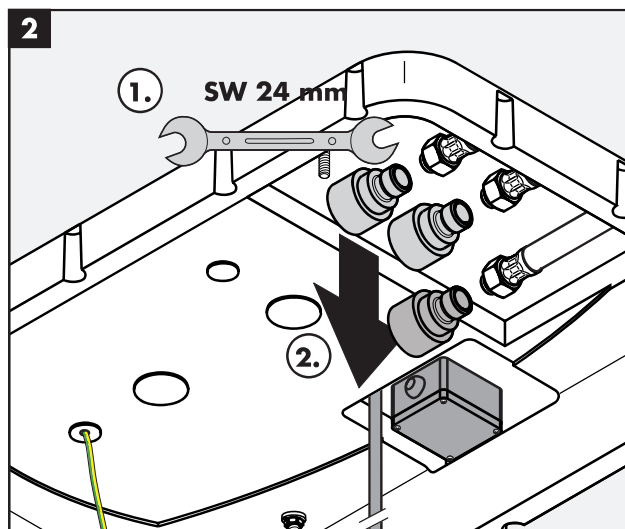
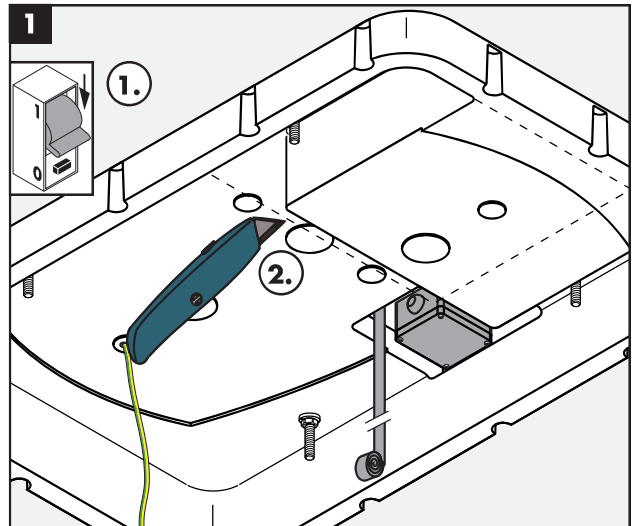
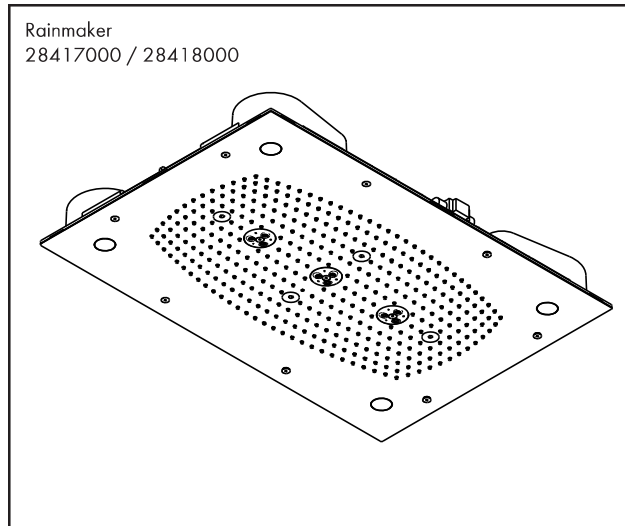
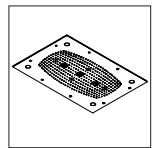

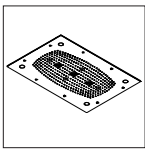

Rainmaker
28417000 / 28418000

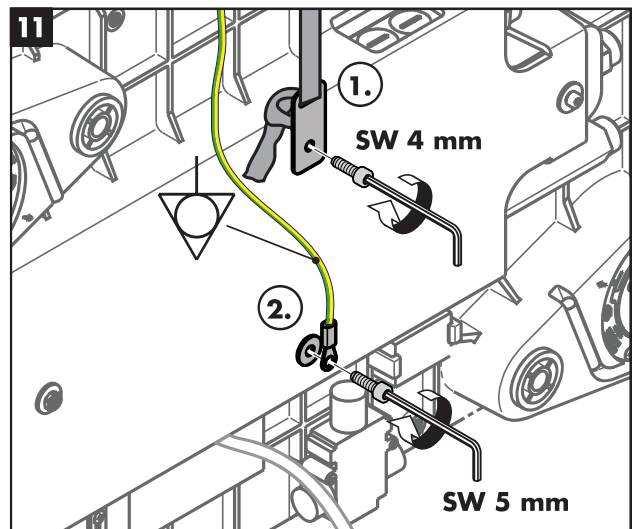
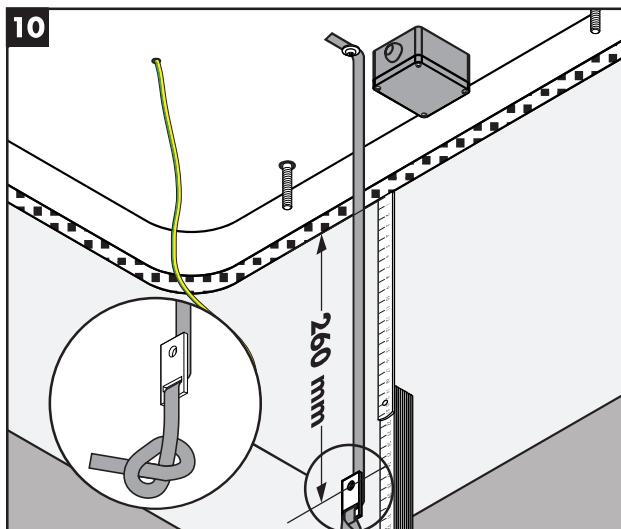
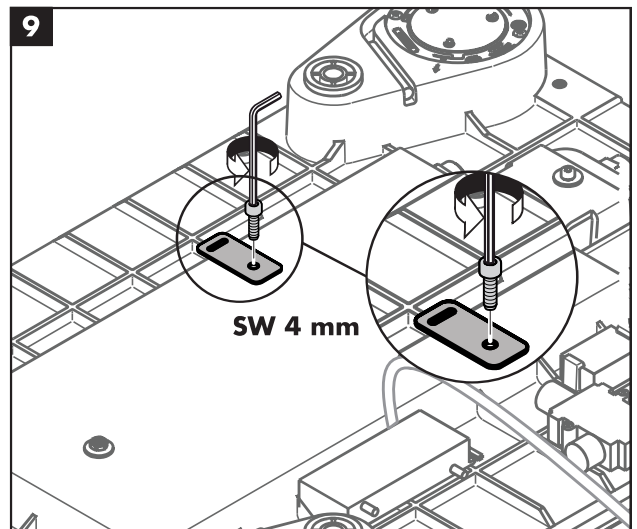
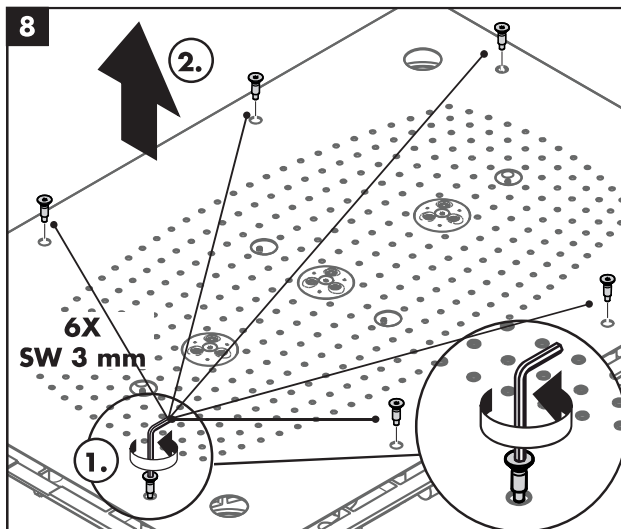
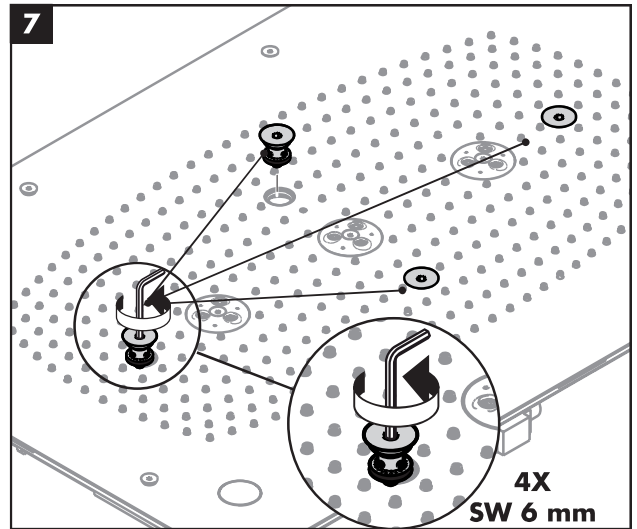
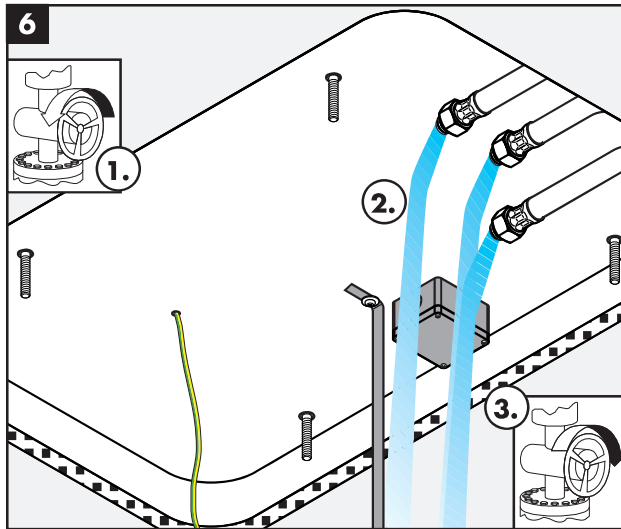

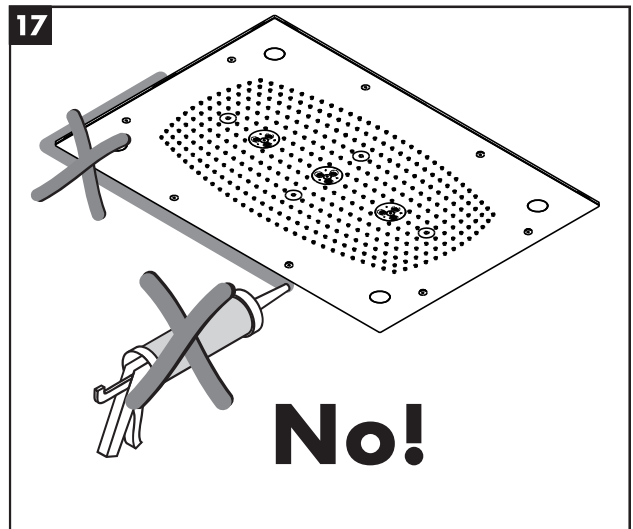
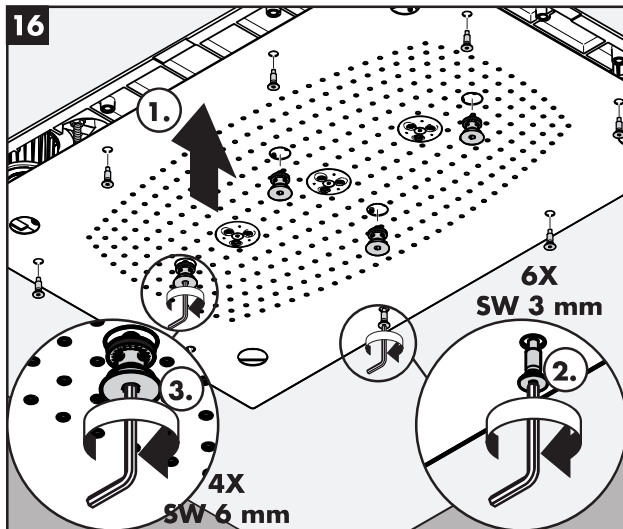
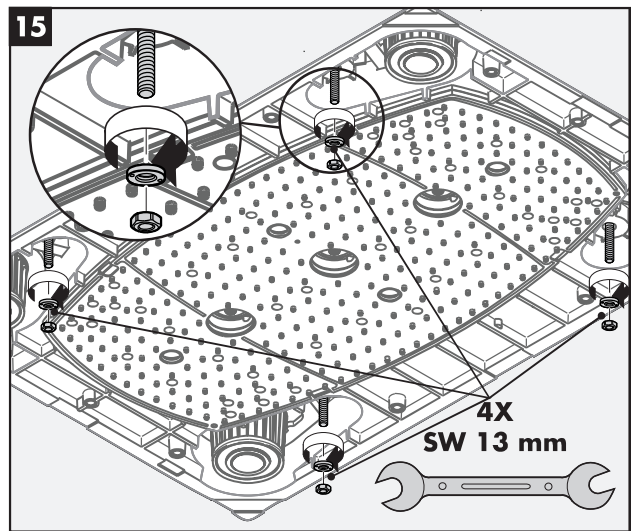
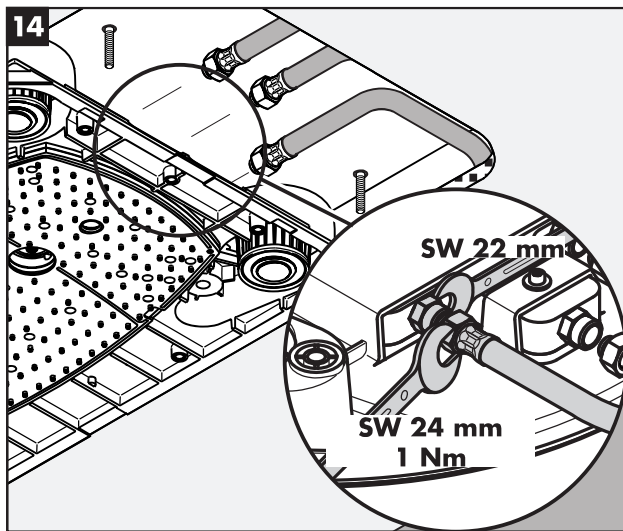
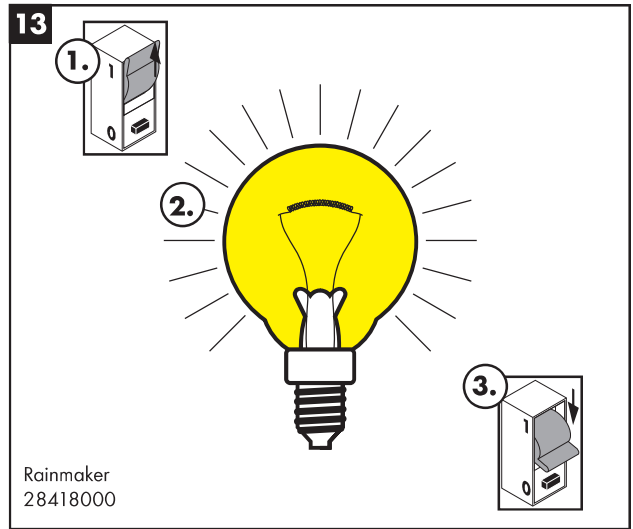
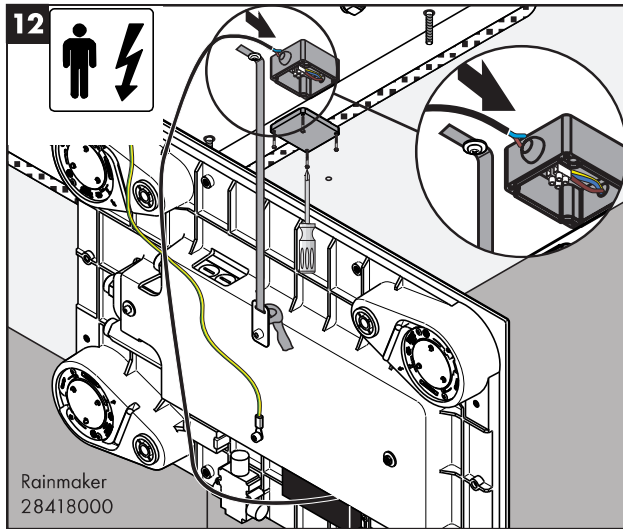
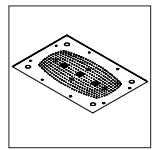

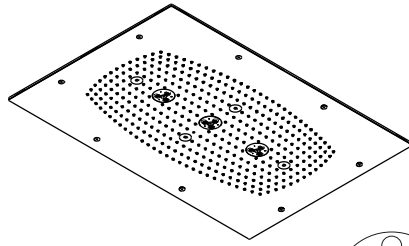

Rain AIR

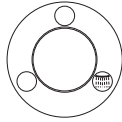

Rain AIR XXL

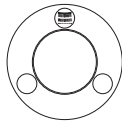

Whirl AIR

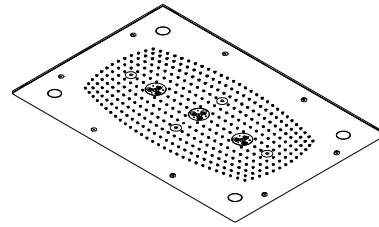
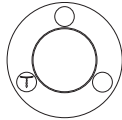

**Whirl AIR +
Rain AIR XXL**

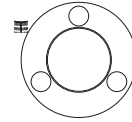

**Whirl AIR +
Rain AIR**

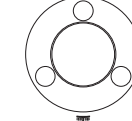

**Rain AIR XXL +
Rain AIR**

