

Multibox



Floor Heating Controller

Flush individual room control for floor heating systems

*Engineering
GREAT Solutions*

Multibox K, RTL and K-RTL

Multibox K, RTL and K-RTL is used for decentralized control of floor or wall heating systems or combined floor/radiator heating systems. For out-of-true installation offsetting up to 6° on each side. Cover with concealed screw connection. Models in white or chrome. Adjustable fitting for all wall structures, 30 mm depth compensation.



Key features

- > For out-of-true installation offsetting up to 6° on each side
- > Cover with concealed screw connection
- > Models in white or chrome
- > Adjustable fitting for all wall structures, 30 mm depth compensation

Technical description

Applications:

Floor heating systems, wall heating systems, combined floor/radiator heating systems

Functions:

Multibox K:

Individual room temperature control, Presetting (V-exact II), Shut-off, Venting

Multibox RTL:

Maximum limitation of the return temperature, Presetting, Shut-off, Venting

Multibox K-RTL:

Individual room temperature control, Maximum limitation of the return temperature, Presetting (V-exact II), Shut-off, Venting

Dimensions:

Valve body DN 15.
The flush box has an overall depth of 60 mm.
Flexible mounting thanks to variable spacing between flush box and cover of up to 30 mm.
The cover can compensate for slanted mounting of the flush box of up to 6° on each side.
See also Dimensions.

Pressure class:

PN 10

Setting range:

Thermostatic head K:
6 °C to 28 °C
Return temperature limiter RTL:
0 °C to 50 °C

Temperature:

Max. working temperature: 90°C
Min. working temperature: 2°C
For all Multibox models, ensure that the system supply temperature is suitable for setting up the floor heating system.
See also Information!

Material:

Valve body: Corrosion resistant Gunmetal
O-rings: EPDM rubber
Valve disc: EPDM rubber
Return spring: Stainless steel
Valve insert: Brass, PPS (polyphenylsulphide)
Spindle: Niro-steel spindle with double O-ring sealing. The outer O-ring can be replaced under pressure.
Plastic parts of ABS and PA.
Sensor element: Thermostatic head K with liquid filled sensor. Return temperature limiter (RTL) filled with an expansible medium.

Surface treatment:

All models optionally with cover and visible graduation cap in white RAL 9016 or chrome-plated.

Marking:

TAH, flow direction arrows, II-Designation.

Pipe connection:

Pipe-side G 3/4 adaptor with cone suitable for compression fittings for plastic, copper, precision steel and multi-layer pipe.

Construction

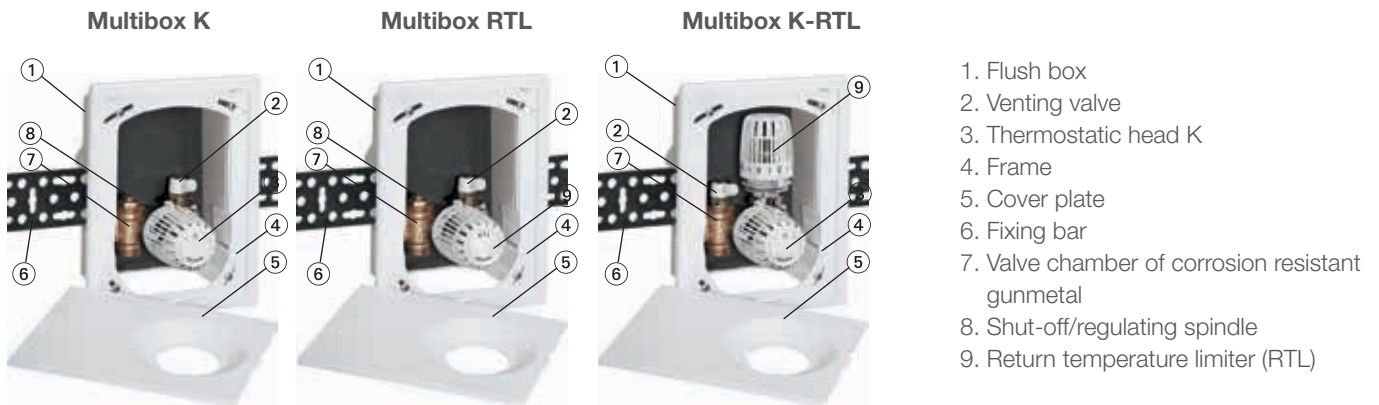

Applications

Multibox K

Multibox K is used for the individual room temperature control of, for instance, floor heating systems in association with low temperature heating systems. Multibox K is also used in wall heating systems.

Use the V-exact II insert for hydraulic balancing.

Multibox RTL

Multibox RTL is used for maximum limitation of the return temperature with, for instance, combined floor/radiator heating systems for temperature control of floor areas. Only the return temperature is controlled.

Use the shut-off/regulating spindle for hydraulic balancing.

Multibox K-RTL

Multibox K-RTL is used for the individual room temperature control and maximum limitation of the return temperature with, for instance, combined floor/ radiator heating systems.

Multibox K-RTL is also used in wall heating systems.

Use the V-exact II insert for hydraulic balancing.

Sample application

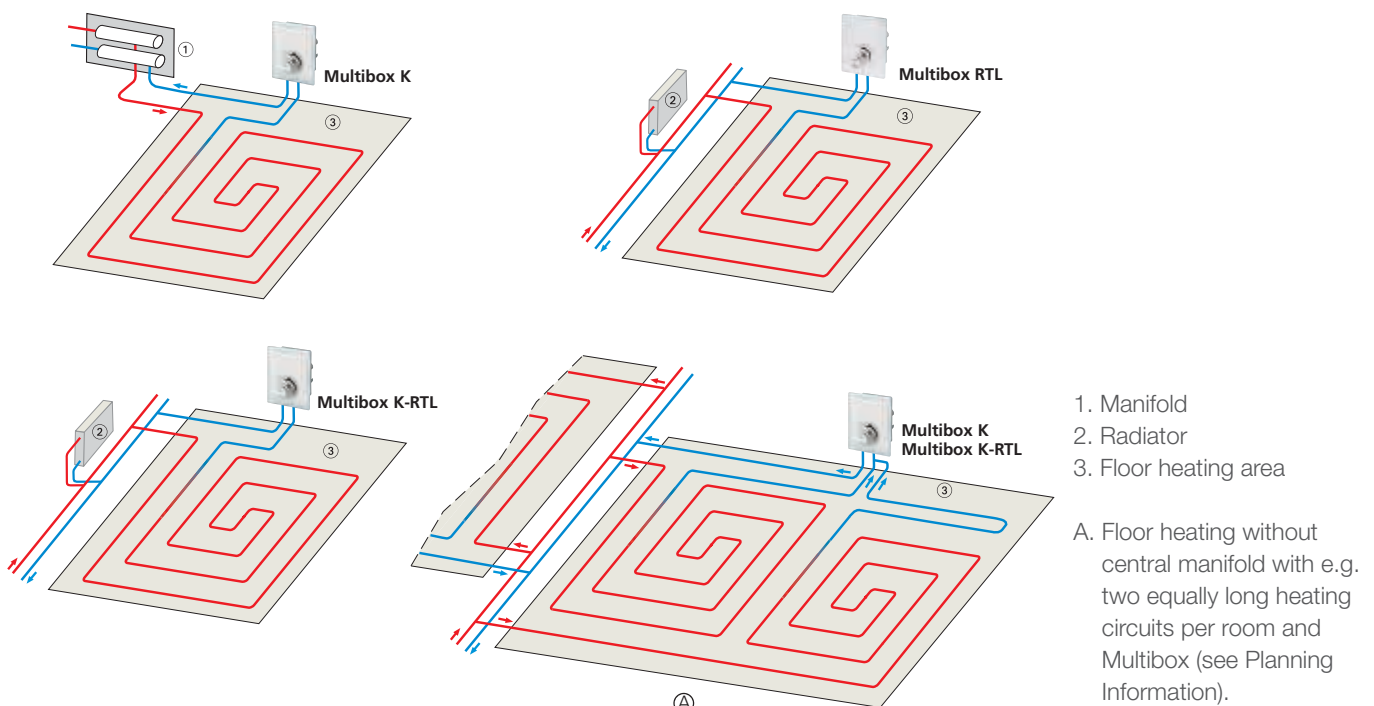

Temperature setting

Thermostatic head K

Cue number	*	1)	2	3	4	5
Room temperature [°C]	6	12	14	16	20	24	28

Return temperature limiter (RTL)

Cue number	0	1	2	3	4	5
Return temperature [°C]	0	10	20	30	40	50

(Opening temperature)

Function

Multibox K

From the control aspect, the thermostatic valve integrated in Multibox K is a constant proportional controller (P-controller) without any auxiliary power. It does not need any electrical connection or other outside power source.

The change of the room air temperature (controlled variable) is proportional to the change of the valve lift (correcting variable). A rise in the room air temperature e.g. from the sun's rays, results in an expansion of the liquid in the temperature sensor and it acts on the bellows.

By means of the valve spindle, this cuts back on the supply of water in the floor heating circuit. The procedure is reversed given a falling room air temperature.

Multibox RTL

From the control aspect, the return temperature limiter integrated in Multibox RTL is a constant proportional controller (P-controller) without any auxiliary power. It does not need any electrical connection or other outside power source.

The temperature change of the fluid flowing through (controlled variable) is proportional to the change of the valve lift (correcting variable) and is transferred to the sensor by means of thermal conduction. Any rise in the return temperature due to, for instance, to lowered heating output of the floor heating system as a result of outside thermal effects causes the substance in the temperature sensor to expand and act on the diaphragm plunger. By means of the valve spindle, this cuts back on the supply of water in the floor heating circuit. The procedure is reversed given a falling fluid temperature.

The valve opens when the set limiting figure is exceeded.

Multibox K-RTL

From the control aspect, the thermostatic valve integrated in Multibox K-RTL is a constant proportional controller (P-controller) without any auxiliary power. It does not need any electrical connection or other outside power source.

The change of the room air temperature (controlled variable) is proportional to the change of the valve lift (correcting variable). A rise in the room air temperature e.g. from the sun's rays, results in an expansion of the liquid in the temperature sensor of the thermostatic head and it acts on the bellows. By means of the valve spindle, this cuts back on the supply of water in the floor heating circuit. The procedure is reversed given a falling room air temperature.

Multibox K-RTL is additionally provided with a return temperature limiter (RTL) which stops the set return temperature from being exceeded. The valve opens when the set limiting figure is exceeded.

Articles

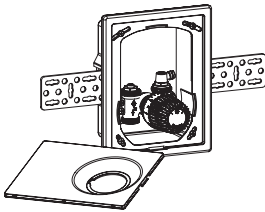

Multibox K

with thermostatic valve

Colour	EAN	Article No
Cover and thermostatic head K white RAL 9016	4024052465019	9302-00.800

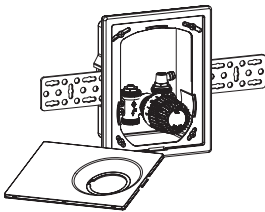

Multibox RTL

with return temperature limiter (RTL)

Colour	EAN	Article No
Cover and RTL thermostatic head white RAL 9016	4024052465217	9304-00.800
Cover and RTL thermostatic head chrome-plated	4024052465316	9304-00.801

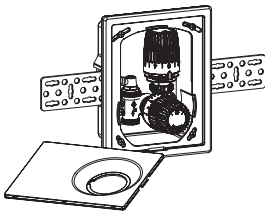

Multibox K-RTL

with thermostatic valve and return temperature limiter (RTL)

Colour	EAN	Article No
Cover and thermostatic head K white RAL 9016	4024052461707	9301-00.800
Cover and thermostatic head K chrome-plated	4024052464913	9301-00.801

Multibox F

Multibox F is used for decentralized room temperature control of underfloor heating.



Key features

- > **No change in appearance irrespective of installation depth**
- > **Elegant and easy-to-clean graduation cap**
- > **For out-of-true installation offsetting up to 6° on each side**
- > **Adjustable fitting for all wall structures, 30 mm depth compensation**

Technical description

Applications:

Floor heating systems, wall heating systems

Functions:

Individual room temperature control
Presetting
Shut-off
Venting

Dimensions:

Valve body DN 15.
The flush box has an overall depth of 60 mm.
Flexible mounting thanks to variable spacing between flush box and cover of up to 30 mm.

Through a capillary tube, the temperature sensor liquid of the thermostatic head acts on the bellows in the valve adaptor. There is therefore never any change in the appearance of the cover with thermostatic head – irrespective of the installation depth.

The cover can compensate for slanted mounting of the flush box of up to 6° on each side.

See also Dimensions.

Pressure class:

PN 10

Setting range:

Thermostatic head F:
6 °C to 28 °C

Temperature:

Max. working temperature: 90°C
Min. working temperature: 2°C
For all Multibox models, ensure that the system supply temperature is suitable for setting up the floor heating system.
See also Information!

Material:

Valve body: Corrosion resistant Gunmetal
O-rings: EPDM rubber
Valve disc: EPDM rubber
Return spring: Stainless steel
Valve insert: Brass, PPS (polyphenylsulphide)
Spindle: Niro-steel spindle with double O-ring sealing. The outer O-ring can be replaced under pressure.
Plastic parts of ABS and PA.
Sensor element: Thermostatic head F with liquid filled sensor.

Surface treatment:

Cover and visible graduation cap in white RAL 9016.

Marking:

TAH, flow direction arrows, II-Designation.

Pipe connection:

Pipe-side G 3/4 adaptor with cone suitable for compression fittings for plastic, copper, precision steel and multi-layer pipe.

Construction

Multibox F

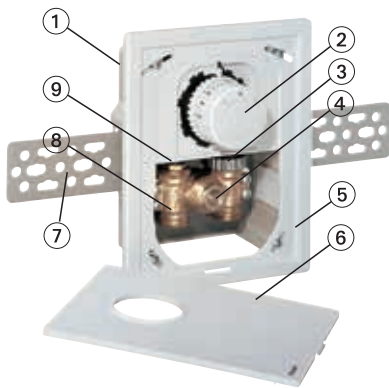

1. Flush box
2. Thermostatic head with capillary tube
3. Adaptor
4. Venting valve
5. Frame
6. Cover plate
7. Fixing bar
8. Valve chamber of corrosion resistant gunmetal
9. Shut-off/regulating spindle

Application

Multibox F

Multibox F is used for the individual room temperature control of, for instance, floor heating systems in association with low temperature heating systems.

Multibox F is also used in wall heating systems. Use the shut-off/regulating spindle for hydraulic balancing.

Sample application

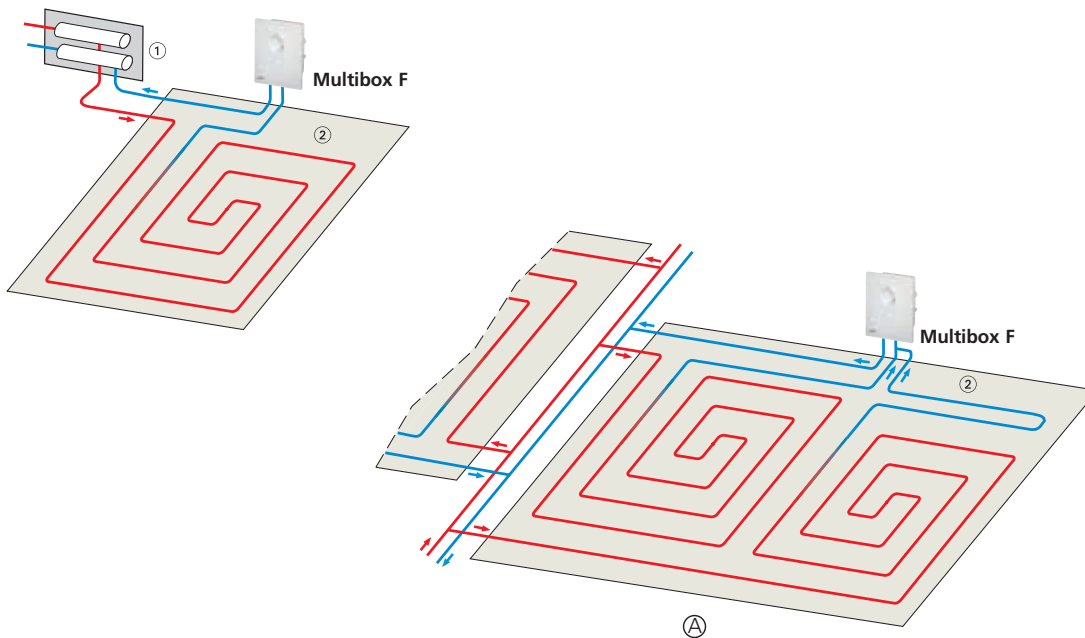

1. Manifold
2. Heating area

A. Floor heating without central manifold with e.g. two equally long heating circuits per room and Multibox (see Planning Information).

Temperature setting

Thermostatic head F

Cue number	*	1)	2	3	4	5
Room temperature [°C]	6	12	14	16	20	24	27

Function

Multibox F

From the control aspect, the thermostatic valve integrated in Multibox F is a constant proportional controller (P-controller) without any auxiliary power. It does not need any electrical connection or other outside power source.

Change of the room air temperature (controlled variable) is proportional to the change of the valve lift (correcting variable).

A rise in the room air temperature e.g. from the sun's rays, results in an expansion of the liquid in the temperature sensor and it acts through the capillary tube on the bellows in the valve adaptor. By means of the valve spindle, this cuts back on the supply of water in the floor heating circuit. The procedure is reversed given a falling room air temperature.

Articles

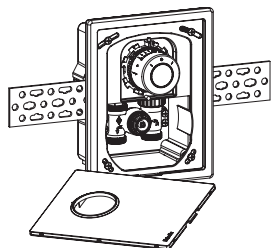

Multibox F with thermostatic valve

Colour	EAN	Article No
Cover and thermostatic head white RAL 9016	4024052508815	9306-00.800

Multibox C/E and C/RTL

Multibox C/E and C/RTL with closed cover plate is used for decentralized temperature control of underfloor heating.



Key features

- > Closed cover plate
- > For out-of-true installation offsetting up to 6° on each side
- > Multibox C/E suitable for actuators or remote dials
- > Adjustable fitting for all wall structures, 30 mm depth compensation

Technical description

Applications:

Floor heating systems, wall heating systems, combined floor/radiator heating systems

Functions:

Multibox C/E:

Individual room temperature control with thermal or motorized actuators or with remote dial thermostatic head F, Presetting, Shut-off, Venting

Multibox C/RTL:

Maximum limitation of the return temperature, Presetting, Shut-off, Venting

Dimensions:

Valve body DN 15.
The flush box has an overall depth of 60 mm.
Flexible mounting thanks to variable spacing between flush box and cover of up to 30 mm.
The cover can compensate for slanted mounting of the flush box of up to 6° on each side.
See also Dimensions.

Pressure class:

PN 10

Setting range:

Return temperature limiter RTL:
0 °C to 50 °C

Temperature:

Max. working temperature: 90°C
Min. working temperature: 2°C
For all Multibox models, ensure that the system supply temperature is suitable for setting up the floor heating system.
See also Information!

Material:

Valve body: Corrosion resistant Gunmetal
O-rings: EPDM rubber
Valve disc: EPDM rubber
Return spring: Stainless steel
Valve insert: Brass, PPS (polyphenylsulphide)
Spindle: Niro-steel spindle with double O-ring sealing. The outer O-ring can be replaced under pressure.
Plastic parts of ABS and PA.
Sensor element: Return temperature limiter (RTL) filled with an expansible medium.

Surface treatment:

Cover in white RAL 9016.

Marking:

TAH, flow direction arrows, II-Designation.

Pipe connection:

Pipe-side G 3/4 adaptor with cone suitable for compression fittings for plastic, copper, precision steel and multi-layer pipe.

Construction

Multibox C/E

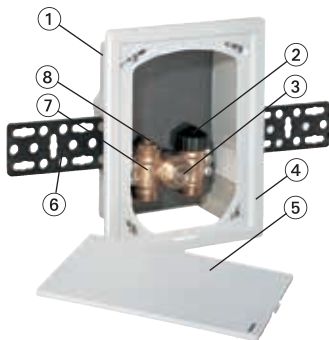

Multibox C/RTL

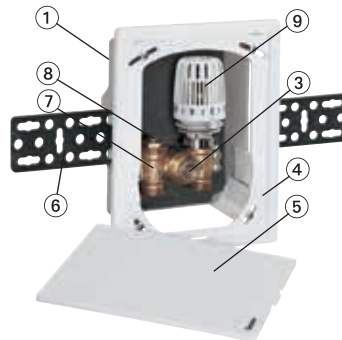

1. Flush box
2. Thermostatic insert for attachment of actuators or remote dials
3. Venting valve
4. Frame
5. Cover plate
6. Fixing bar
7. Valve chamber of corrosion resistant gunmetal
8. Shutoff/regulating spindle
9. Return temperature limiter (RTL)

Application

Multibox C/E

Multibox C/E is used for the individual room temperature control of, for instance, floor heating systems in association with low temperature heating systems.

The individual room temperature is controlled by room thermostats in association with thermal or motorized actuators and/or without auxiliary power with the thermostatic head F remote dial.

Multibox C/E is also used in wall heating systems.

Use the shut-off/regulating spindle for hydraulic balancing.

Multibox C/RTL

Multibox C/RTL is used for maximum limitation of the return temperature with, for instance, combined floor/radiator heating systems for the temperature control of floor areas.

Only the return temperature is controlled.

Use the shut-off/regulating spindle for hydraulic balancing.

Sample application

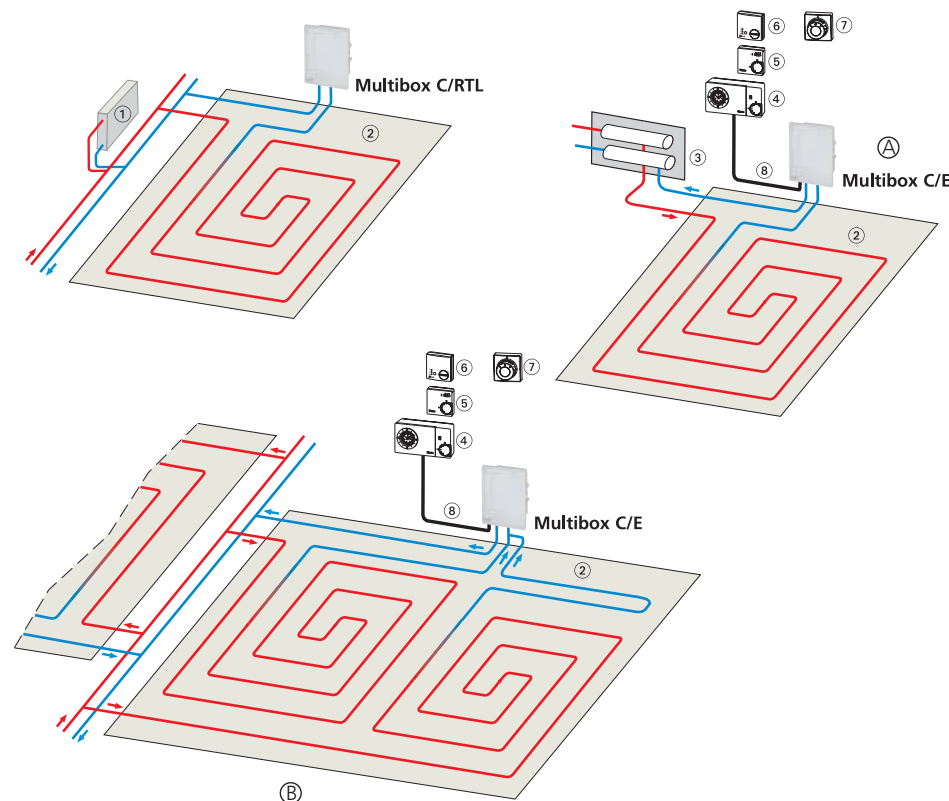

1. Radiator
 2. Floor heating area
 3. Manifold
 4. Thermostat P
 5. Room thermostat
 6. Thermostat E
 7. Thermostatic head F, Remote dial
 8. Empty pipe for cable and/or cap. tube
- A. With thermal actuator EMO T, EMOTec, motorized actuator EMO 1/3/EIB/LON or thermostatic head F
- B. With e.g. two equally long heating circuits per room and Multibox (see Planning information).

Temperature setting

Return temperature limiter (RTL)

Cue number	0	1	2	3	4	5
Return temperature [°C]	0	10	20	30	40	50

(Opening temperature)

Function

Multibox C/E

From the control aspect, the thermostatic valve integrated in Multibox C/E – in association with Thermostatic head F – is a constant proportional controller (P-controller) without auxiliary power. It does not need any electrical connection or other outside power source.

Change of the room air temperature (controlled variable) is proportional to the change of the valve lift (correcting variable). A rise in the room air temperature e.g. from the sun's rays, results in an expansion of the temperature sensor liquid and it acts through the capillary tube on the corrugated tube in the valve adaptor. By means of the valve spindle, this cuts back on the supply of water in the floor heating circuit. The procedure is reversed given a falling room air temperature.

Together with thermal or motorized actuators, room thermostats control individual room temperature.

Multibox C/RTL

From the control aspect, the return temperature limiter integrated in Multibox C/RTL is a constant proportional controller (P controller) without any auxiliary power. It does not need any electrical connection or other outside power source.

Temperature change of the fluid flowing through (controlled variable) is proportional to the change of the valve lift (correcting variable) and is transferred to the sensor by means of thermal conduction.

Any rise in the return temperature due to, for instance, to a lowered heating output of the floor heating system as a result of outside thermal effects causes the substance in the temperature sensor to expand and act on the diaphragm plunger. By means of the valve spindle, this cuts back on the supply of water in the floor heating circuit. The procedure is reversed given a falling fluid temperature.

The valve opens when the set limiting figure is exceeded.

Articles

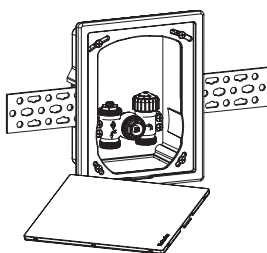

Multibox C/E

with thermostatic insert for actuator or remote dial

Colour	EAN	Article No
Cover white RAL 9016	4024052519118	9308-00.800

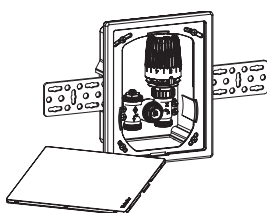

Multibox C/RTL

with return temperature limiter (RTL)

Colour	EAN	Article No
Cover white RAL 9016	4024052507818	9303-00.800

Information

Planning notes

- **For all Multibox models, ensure that the system supply temperature is suitable for setting up the floor heating system.**
- **All Multibox models are to be connected to the return pipe at the end of the floor heating circuit. Heed direction of flow (see Examples of use).**
- Depending on piping pressure loss, all Multibox models are suitable for heating areas up to approx. 20 m².
- The length of 12 mm internal diameter pipe in any heating circuit should not exceed 100 m.
- With heating areas >20 m² and/or pipe lengths >100 m, a T-piece, for instance, should be used to connect two equally long heating circuits to the Multibox. (see Examples of use).
- To ensure low-noise system operation, differential pressure over the valve should not exceed 0.2 bar.
- The floor heating pipe is to be laid spirally in the flooring screed (see Examples of use).
- The set value of the RTL should not be below ambient temperature - otherwise it will not open.

Thermal fluid

To stop any damage and scale in hot water heating systems, the composition of the thermal fluid is to conform to VDI Directive 2035. For industrial and longdistance energy systems, see applicable codes VdTÜV and 1466/AGFW FW 510.

Mineral oil in the thermal fluid and/or all kinds of lubricants containing mineral oil lead to considerable swelling and, in most cases, to the failure of EPDM seals.

When using nitrite-free antifreeze and anti-corrosive based on ethylene glycol, technical advice – especially on additive concentration – is to be taken from the anti-freeze/anti-corrosive manufacturer's documentation.

Functional heating

Carry out functional heating of heating screed conforming to standards in keeping with EN 1264-4.

Earliest start for functional heating:

- Cement screed: 21 days after laying
 - Anhydrite screed 7 days after laying
- Begin 20 °C - 25 °C flow temperature and maintain for 3 days. Then set maximum design temperature and maintain for 4 days. Flow temperature can be regulated by controlling the heat generator. Turn the protective cap anticlockwise to open valve or turn RTL head to Position 5.
Refer to the screed manufacturer's information!

Do not exceed maximum floor temperature at the heating pipes:

- Cement and anhydrite screed: 55 °C
- Poured asphalt screed: 45 °C
- according to screed manufacturer's technical advice!

Technical data – Multibox K and K-RTL

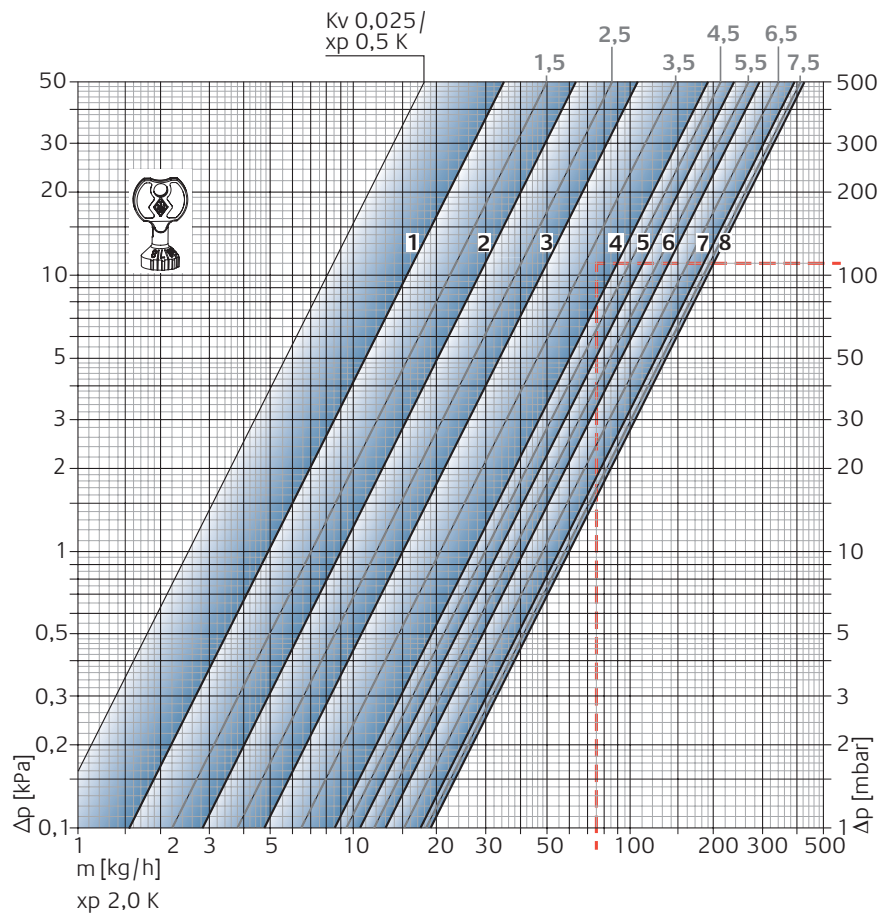

Valve body with thermostatic head

		Presetting							
		1	2	3	4	5	6	7	8
P-band [xp]	Kv-value	0,049	0,082	0,130	0,215	0,246	0,303	0,335	0,343
1.0K									
P-band [xp]	Kv-value	0,049	0,090	0,150	0,265	0,330	0,409	0,560	0,600
2.0K									
	Kvs	0,049	0,102	0,185	0,313	0,332	0,518	0,619	0,670

$K_v/K_{vs} = m^3/h$ at a pressure drop of 1 bar.

Sample calculation

To be found:

Setting range

Given:

Heat flow $Q = 1308 \text{ W}$

Temperature spread $\Delta T = 15 \text{ K}$ (65/50 °C)

Pressure loss Multibox K, Multibox K-RTL $\Delta p_V = 110 \text{ mbar}$

Solution:

Mass flow $m = Q / (c \cdot \Delta T) = 1308 / (1,163 \cdot 15) = 75 \text{ kg/h}$

Setting range from Diagram:

With P-band **max. 2.0 K**: 4

$$C_v = \frac{K_v}{0,86}$$

$$K_v = C_v \cdot 0,86$$

Technical data – Multibox RTL and C/RTL

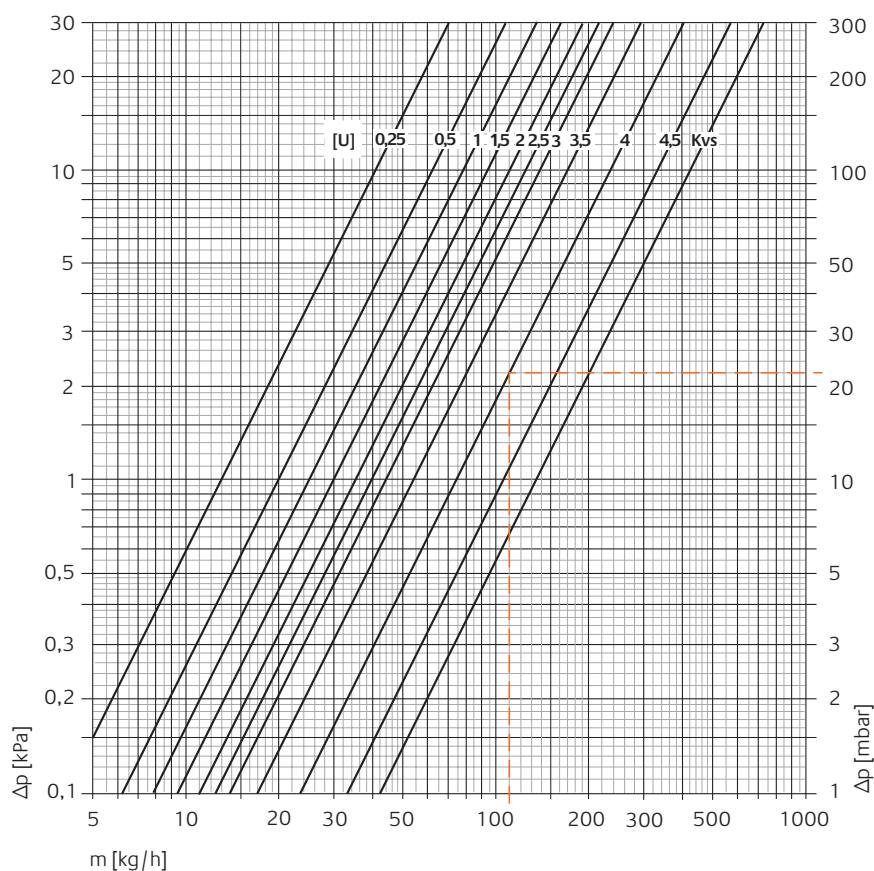

Controller with valve body

DN 15	Kv-value Multibox RTL, C/RTL										Kvs
	Regulating spindle										
	0,25	0,5	1,0	1,5	2,0	2,5	3,0	3,5	4,0	4,5	5,0
	0,13	0,20	0,25	0,30	0,35	0,39	0,44	0,54	0,74	1,06	1,35

$Kv/Kvs = m^3/h$ at a pressure drop of 1 bar.

Sample calculation

To be found:

Preset figure Multibox RTL, C/RTL

Given:

Thermal flux $Q = 1025 \text{ W}$

Temperature spread $\Delta t = 8 \text{ K}$ ($44/36^\circ \text{ C}$)

Pressure loss Multibox RTL $\Delta p_v = 22 \text{ mbar}$

Solution:

Mass flow $m = Q / (c \cdot \Delta t) = 1025 / (1,163 \cdot 8) = 110 \text{ kg/h}$

$$Cv = \frac{Kv}{0,86}$$

Preset figure from diagram: 4

$$Kv = Cv \cdot 0,86$$

Technical data – Multibox F and C/E*)

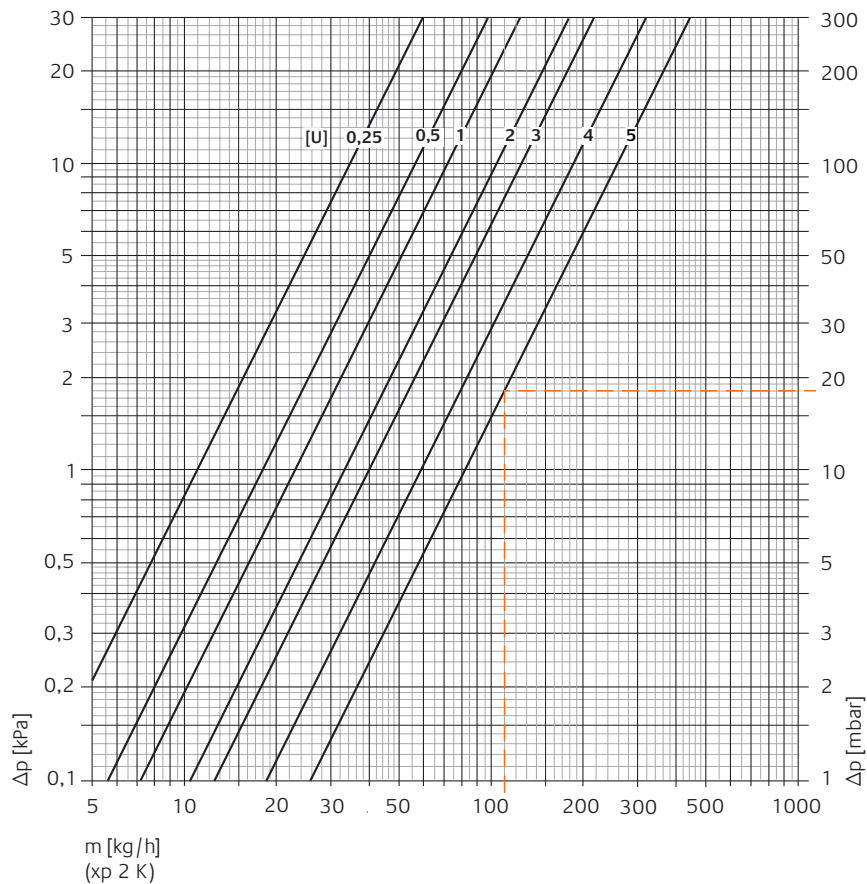

Controller with valve body

DN 15	P-band Th. head xp [K]	Kv-value Multibox F, C/E *)							Kvs
		Preset rotations [U] Regulating spindle							
		0,25	0,5	1,0	2,0	3,0	4,0	5,0	
1	0,10	0,17	0,21	0,28	0,32	0,39	0,43	1,35	
2	0,11	0,18	0,23	0,33	0,40	0,59	0,82		

$K_v/K_{vs} = m^3/h$ at a pressure drop of 1 bar.

*) together with thermostatic head F

Sample calculation

To be found:

Pressure loss Multibox F, C/E at 2 K p-band xp

Given:

Thermal flux $Q = 1025 \text{ W}$

Temperature spread $\Delta t = 8 \text{ K}$ ($44/36^\circ \text{ C}$)

Solution:

Mass flow $m = Q / (c \cdot \Delta t) = 1025 / (1,163 \cdot 8) = 110 \text{ kg/h}$

Pressure loss as diagram $\Delta p_v = 18 \text{ mbar}$

$$C_v = \frac{K_v}{0,86}$$

$$K_v = C_v \cdot 0,86$$

Accessories

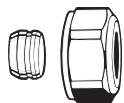

Compression fitting

for copper or precision steel pipe.
Brass nickel-plated.
With a pipe wall thickness of 0.8-1 mm
insert supporting sleeves. Heed pipe
manufacturer's technical advice.

Ø Pipe	EAN	Article No
12	4024052214211	3831-12.351
15	4024052214617	3831-15.351
16	4024052214914	3831-16.351
18	4024052215218	3831-18.351



Support sleeve

for copper or precision steel pipe with a 1
mm wall thickness.
Brass.

Ø Pipe	L	EAN	Article No
12	25,0	4024052127016	1300-12.170
15	26,0	4024052127917	1300-15.170
16	26,3	4024052128419	1300-16.170
18	26,8	4024052128815	1300-18.170

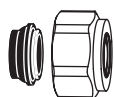

Compression fitting

for copper or precision steel pipe.
Brass nickel-plated.
Soft sealed.

Ø Pipe	EAN	Article No
15	4024052515851	1313-15.351
18	4024052516056	1313-18.351



Compression fitting

for plastic pipe.
Brass nickel-plated.

Ø Pipe	EAN	Article No
14x2	4024052134618	1311-14.351
16x2	4024052134816	1311-16.351
17x2	4024052134915	1311-17.351
18x2	4024052135110	1311-18.351
20x2	4024052135318	1311-20.351



Compression fitting

for multi-layer pipes.
Nickel-plated brass.

Ø Pipe	EAN	Article No
16x2	4024052137312	1331-16.351

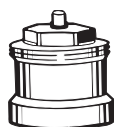

Spindle extension for K thermostatic head with Multibox K and Multibox K-RTL

when maximum installation depth
exceeded.

L	EAN	Article No
Brass nickel-plated		
20	4024052528813	2201-20.700
30	4024052528912	2201-30.700
Plastic, black		
15	4024052553310	2001-15.700
30	4024052165018	2002-30.700

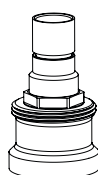

Spindle extension for RTL thermostatic head with Multibox RTL

when maximum installation depth
exceeded.
Brass nickel-plated.

L	EAN	Article No
20	4024052500215	9153-20.700

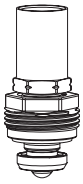

Replacement insert for Multibox RTL from 08.2013
for valve bodies with II-marking.

EAN	Article No
4024052909711	1305-02.300



V-exact II replacement insert for Multibox K and Multibox K-RTL from 08.2013
for valve bodies with II-marking.

EAN	Article No
4024052841417	3700-02.300

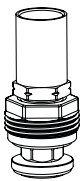

Special insert for Multibox RTL up to 08.2013
for reversed direction of flow with
switched supply and return flow.

EAN	Article No
4024052492619	9304-03.300



RTL insert and RTL thermostatic head
specially for converting Multibox K/
Multibox AFC K into Multibox K-RTL/
Multibox AFC K-RTL.

	EAN	Article No
RTL insert	4024052497812	9303-00.300
RTL thermostatic head	4024052275311	6500-00.500

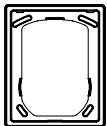
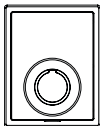

Frame and cover plate
Replacement for Multibox K/Multibox
AFC K, Multibox RTL/Multibox AFC RTL
and Multibox K-RTL/Multibox AFC K-RTL.

Colour	EAN	Article No
White RAL 9016	4024052489671	9300-00.800

Dimensions – Multibox K, RTL, K-RTL

Multibox K

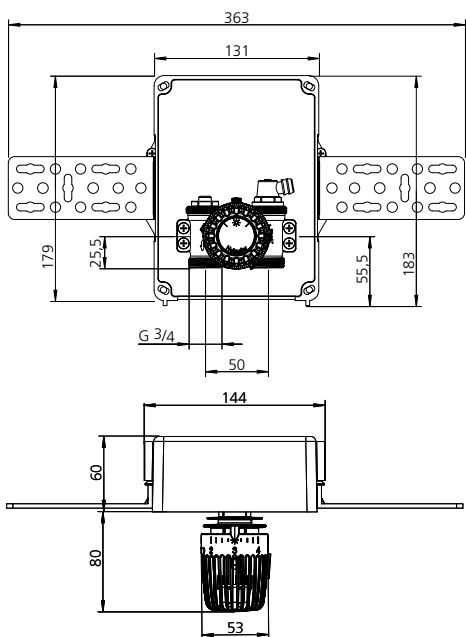

Multibox RTL

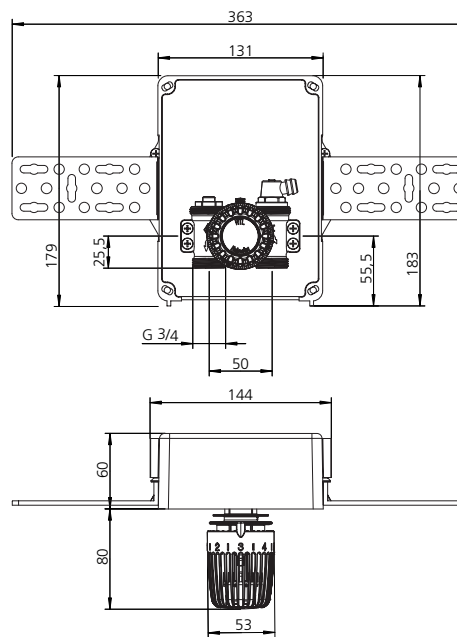

Multibox K-RTL

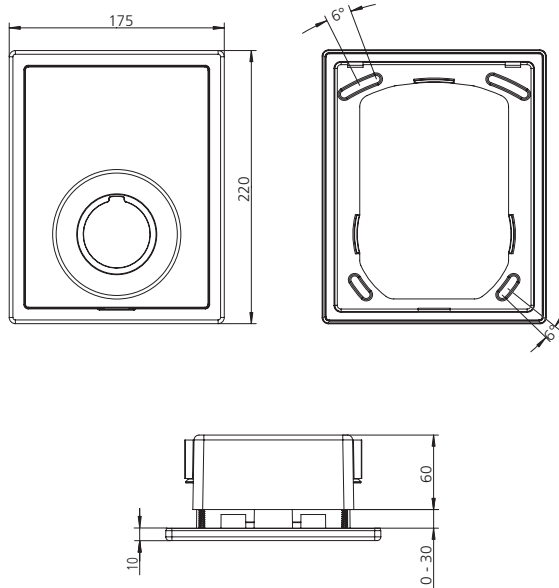
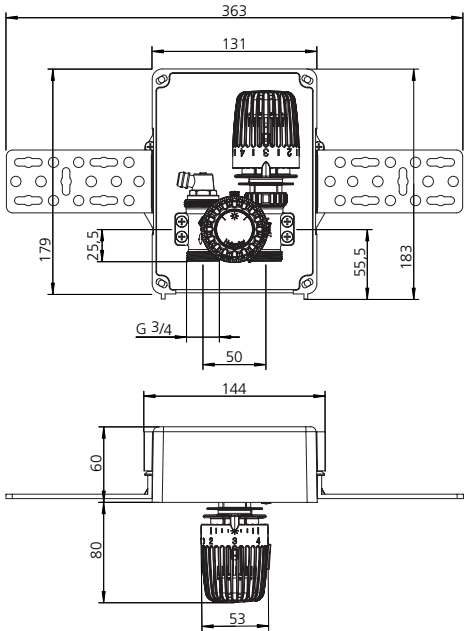

Dimensions – Multibox F

Multibox F

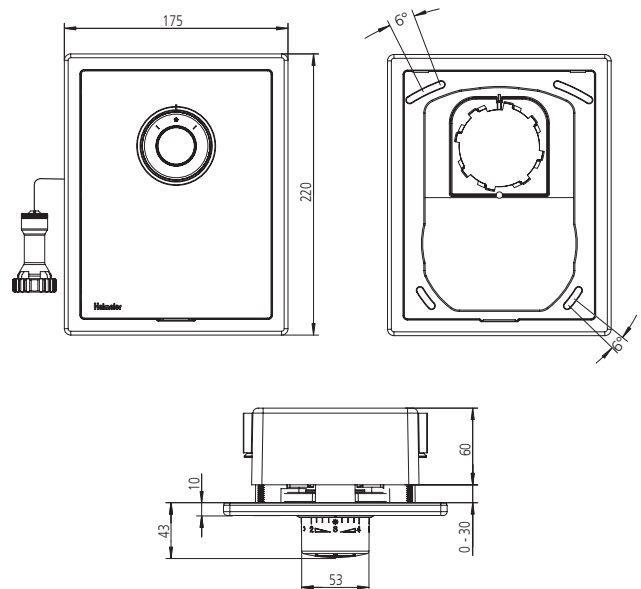
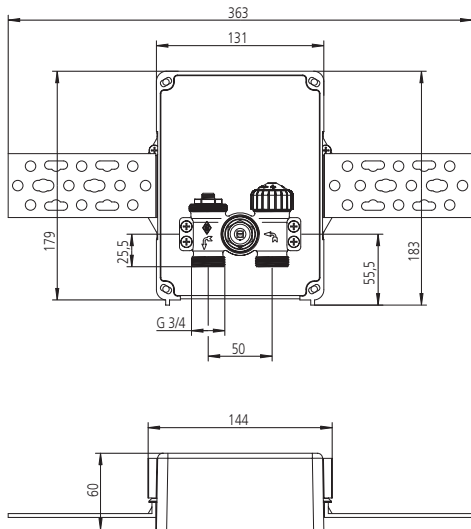

Dimensions – Multibox C/E and C/RTL

Multibox C/E

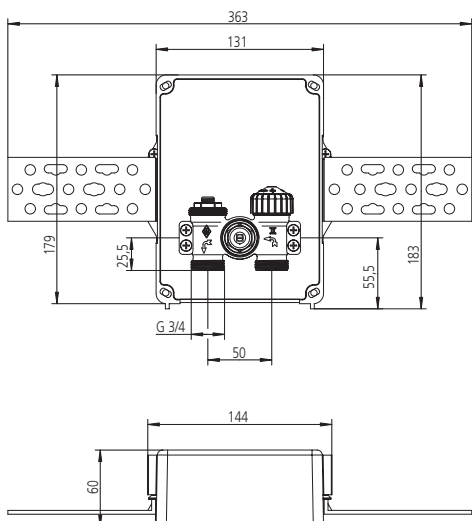

Multibox C/RTL

