



This product should only be fitted by a qualified plumber to NVQ (National Vocational Qualification) or SNVQ (Scottish National Vocational Qualification) Level 3. Should the installation be completed by a non-qualified person then the guarantee may be considered invalid.

For a claim made under our warranty written certification of your installers credentials can be required. For further information or to find a qualified installer in your area please visit the Institute of Plumbers website - [www.iphe.org.uk](http://www.iphe.org.uk)

## THE QUALIFICATIONS

At present, to be a plumber you need to follow the National Vocational Qualification (NVQ) route (Scottish National Vocational Qualification - SNVQ - in Scotland). These qualifications are made up of theory and practical work in the classroom/purpose built training facility and work based experience with a working plumber. Colleges should help students find a work placement, although many students organise it themselves.

The S/NVQ qualification works in levels. All recently qualified plumbers should hold S/NVQ Level 2 as basic with Level 3 as the preferred level. Level 2 will give you the foundation you need for a career in plumbing and teach you domestic plumbing to a satisfactory level. Level 3 is more comprehensive and deals with domestic, commercial and industrial plumbing along with aspects such as gas - if you want to one day set up your own business, this is the level to reach. The Institute of Plumbing and Heating Engineering, and the industry as a whole recommends that all plumbers reach a minimum of Level 3.

Reaching Level 3 has other advantages. The Institute runs a Master Plumber Certificate, which only those attaining Level 3 or equivalent can reach as long as they have the relevant experience as well. Those with S/NVQ Level 3 can (once in membership with the Institute for five years as a Member MIPHE) gain Engineering Technician EngTech status with the Engineering Council (UK).

For any further information please email [technical@adora-bathrooms.co.uk](mailto:technical@adora-bathrooms.co.uk)

Or visit our web-site at [www.adora-bathrooms.co.uk](http://www.adora-bathrooms.co.uk)

The manufacturer reserves the right to make technical modifications without prior notice.

## Thermostatic Bar Valve

MB500RM

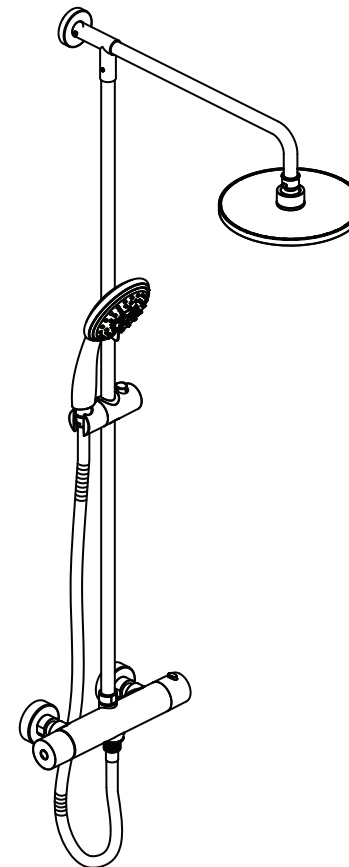

## INSTALLATION INSTRUCTIONS

ADORA

## INSTRUCTION

Thank you for purchasing a quality Adora product. To enjoy the full potential of your new product, please take time to read this guide thoroughly, having done so, keep it handy for future reference.

### General

The Adora Fusion thermostatic bar valve is a thermostatic shower control designed for wall mount installations.

The thermostatic bar valve has two knobs, one knob controls the flow rate & flow direction and the other knob controls the temperature.

The Adora Fusion TMV is supplied with a deluge head, rigid riser, a three mode showerhead and shower fittings kit.

The thermostatic bar valve incorporates a wax capsule temperature sensing unit, which provides an almost immediate response to changes in pressures or temperature of the incoming water supplies, to maintain the selected temperature. An adjustable maximum temperature stop is provided which limits the temperature to a safe level. Inlet filters are fitted to protect the thermostatic cartridge.

### Pressures

- Max Static Pressure: **10 Bar**
- Max Maintained Pressure: **5 Bar**
- Min Maintained Pressure: **0.5 Bar**

### Temperatures

- Optimum thermostatic control range: **38°C to 46°C** (achieved with supplies of 15°C cold and 65°C and nominally equal pressures).
- Recommended Hot Supply: **60°C to 65°C**
- Cold Water Range: **5°C to 25°C**

### Thermostatic Shut-down

For safety, The valve will shut off **within 2 seconds** if cold supply fails.

## MAINTAINING THE NON-RETURN VALVE

The non-return valves are located in the thermostatic bar valve body, and are accessible through the inlet connectors.

**Caution!** Make sure that the non-return valves are installed correctly to prevent crossflow or malfunction of the valve.

1. With the water supplies turned off and the thermostatic bar valve removed, remove the sealing washer / filter.
2. Unscrew the non-return valve housing using a 12 mm hexagonal wrench.  
**Note!** The non-return valve housing has a Left Hand Thread, turn clockwise to unscrew.
3. Carefully remove the non-return valve and clean any debris.
4. On re assembly make sure that the non-return valve is fitted the correct way round.

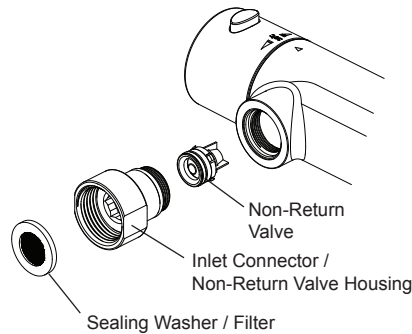

## INSTRUCTION

### Safe Warning

The function of a thermostatic mixing valve is to deliver water consistently at a safe temperature. In keeping with every other mechanism, it can't be considered as functionally infallible and as such, can't totally replace a supervisor's vigilance where that is necessary. Provided it is installed, commissioned, operated and maintained within manufacturer's recommendations, the risk of failure, if not eliminated, is reduced to the minimum achievable.

Adora thermostatic mixers are precision engineered and should give continued safe and controlled performance, provided:

1. They are installed, commissioned, operated and maintained in accordance with the manufacturer's recommendations.
2. Periodic attention is given, when necessary, to maintain the product in good functional order.

### Caution!

1. Read all of these instructions.
2. Retain this guide for later use.
3. Pass on this guide in the event of change of ownership of the installation site.
4. Follow all warnings, cautions and instructions contained in this guide.
5. Anyone who may have difficulty understanding or operating the controls of any shower should be attended whilst showering. Particular consideration should be given to the young, the elderly, the infirm or anyone inexperienced in the correct operation of the controls.
6. Rapid/Excessive movement of the flow and/or temperature control levers may result in momentary unstable blend temperatures.
7. Care is required when adjusting flow or temperature, make sure that the temperature has stabilised.
8. When this product has reached the end of its serviceable life, it should be disposed of in a safe manner, in accordance with current local authority recycling, or waste disposal policy.

## DIMENSIONS

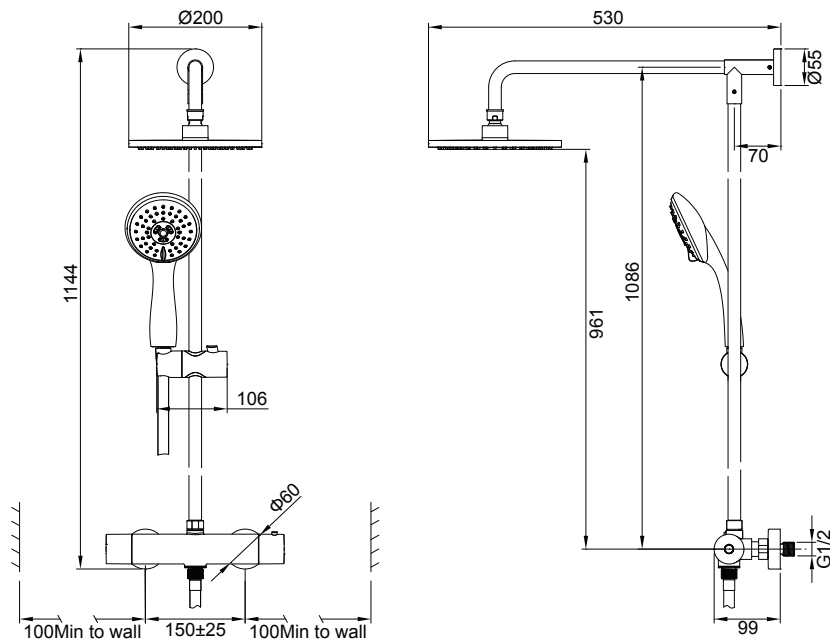

**NOTE: ALL DIMENSIONS IN MILLMETRES**

## FILTERS

The sealing washers / filters are located in the inlet connector. Clean or renew as necessary.

## LUBRICANTS

Silicone based lubricants must only be used on the rubber seals.

**Caution!** Oil based or other lubricant types may cause rapid deterioration of seals.

## CLEANING

The chrome plated parts should be cleaned using a mild washing up detergent or soap solution, rinsed and then wiped dry with a soft cloth.

**Warning!** Many household cleaners contain abrasive and chemical substances, and should not be used for cleaning plated or plastic fittings. Do not use descalents on this product.

## FAULT DIAGNOSIS

### Symptom:

- Only hot or cold water from the mixer outlet.
- Outlet temperature too hot / too cold.

### Cause / Rectification:

- Inlets reversed (hot supply to cold supply).  
Rework inlet pipework.
- No hot or cold water reaching the mixer.
- Check the filters for any blockage.
- Installation conditions outside operating parameters, refer to sections: 'Specifications' and 'Commissioning'

### Symptom:

- Fluctuating or reduced flow rate.

### Cause / Rectification:

- Check the showerhead, hose and filters for any blockage.
- Make sure that the maintained inlet pressures are nominally balanced and sufficient, refer to section: 'Specifications'.
- Make sure that the inlet temperature differentials are sufficient, refer to section: 'Specifications'.
- Flow regulator fitted incorrectly.
- Air lock or partial blockage in the pipework.

### Symptom:

- Water leaking from showerhead.

### Cause / Rectification:

- Normal for a short period after shut off.
- Check that the pressures are not in excess of the specifications for the product.
- Cartridge inlet seals damaged, renew.
- Renew the thermostatic cartridge.

## PACK CONTENTS

Tick the appropriate boxes to familiarise yourself with the part names and to confirm that all of the parts are included.

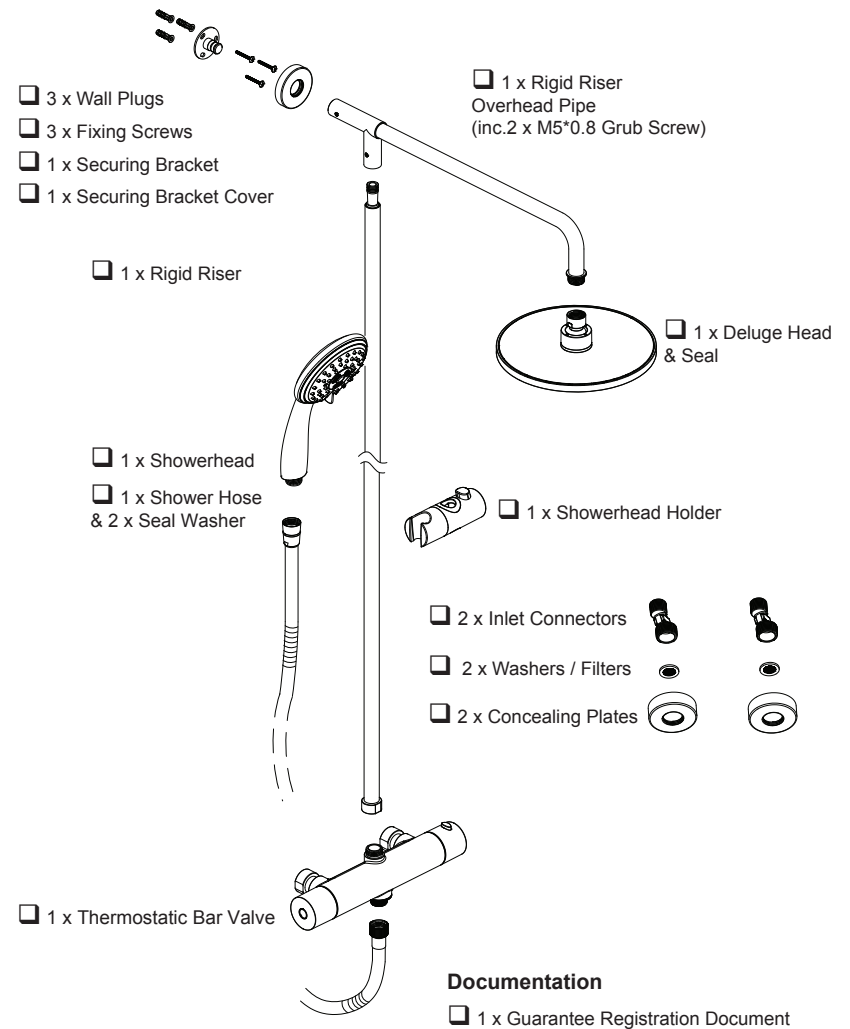

## INSTALLATION

### Suitable Plumbing Systems

#### Gravity Fed:

The thermostatic mixer must be fed from a cold water cistern (usually fitted in the loft space) and a hot cylinder (usually fitted in the airing cupboard) providing normally pressures.

#### Gas Heated System:

The thermostatic mixer can be installed with a combination boiler.

#### Unvented Mains Pressure System:

The thermostatic mixer can be installed with an unvented, stored hot water system.

#### Mains Pressurised Instantaneous Hot Water System:

The thermostatic mixer can be installed with systems of this type with balanced pressures.

#### Pumped System:

The thermostatic mixer can be installed with a inlet pump (twin impeller). The pump must be installed on the floor next to the hot cylinder.

### General

Installation must be carried out in accordance with these instructions, and must be conducted by designated, qualified and competent personnel. The installation must comply with the "Water Supply Regulation 1999(Water Fittings)" or any particular regulations and practices, specified by local water company or water undertakers.

**Note!** Make all site requirements correspond to the information given in section 'Specification'.

1. The mixer must not be installed in an area where may be freeze.
2. For stud partitions, alternative fixings may be required.
3. Isolation valves must be installed close to the mixer for ease of maintenance.
4. Pipeworks must be rigidly supported and avoid any strain on the connections.
5. Pipework dead-legs should be kept to a minimum.
6. All pipework must be checked for leaks before the product installation is completed. The product should be pressurised & the inlet & outlet connections inspected.
7. **Do not** overtighten the grub screws as the product damage may occur. Use hexagonal key provided and hand tighten only. Do not use power tools.

## OPERATION

### Adjusting the Temperature

The temperature is controlled by rotating the temperature knob. For safety reasons, the temperature is limited by an override stop. To obtain a higher temperature, press the override button on the temperature knob and continue to rotate.

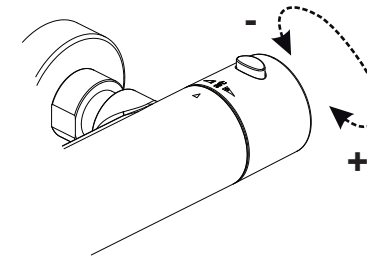

### Adjusting the Flow rate/Flow direction

Both the flow rate and flow direction are controlled by rotating the flow knob.

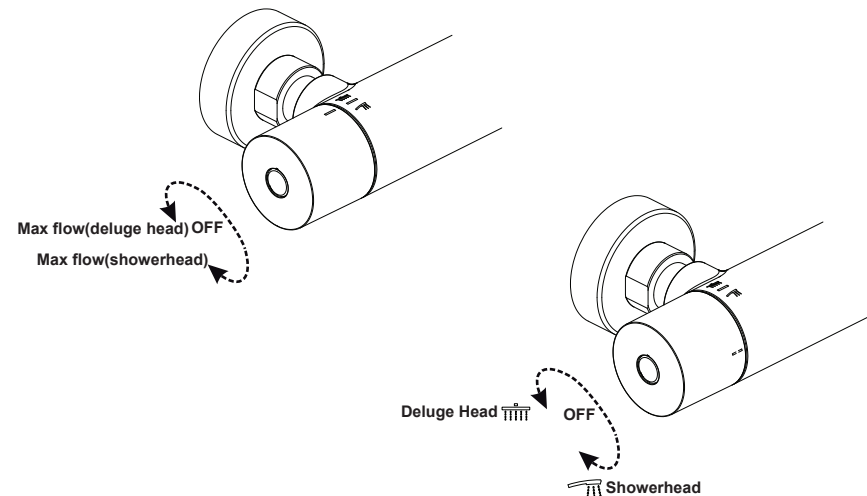

## COMMISSIONING

### Maximum Temperature Setting

Before using the shower the maximum temperature must be checked to make sure that it is at a safe level. It has been preset to a safe showering temperature under ideal conditions at the factory, appropriate for most systems. However, site conditions and personal preference may make it necessary to reset this temperature.

**Note!** Make sure that the hot water temperature is at least 55°C and that there is sufficient supply.

**Caution!** Before testing the mixer, make sure that the hot and cold water is flowing correctly by exercising the temperature selector knob between the cold and hot stops.

1. Depress the override button and turn the temperature knob to reach the maximum water temperature from the outlet. If the water temperature is not hot enough, complete the following procedures.
2. Rotate the temperature knob back to 38°C.
3. Using a suitable screwdriver carefully prise off the concealing cap and unscrew the screw.
4. Pull off the temperature knob without disturbing the stop assembly.
5. Pull off the stop assembly, turn an angle anticlockwise and replace it.
6. Replace the temperature knob.

**Note:** The 38°C mark on the knob should be in line with the red triangle mark on the mixer body.

7. Rotate the temperature knob to reach the maximum water temperature and then test after the temperature stabilises.
8. If the water temperature is still not hot enough, repeat the procedures above.

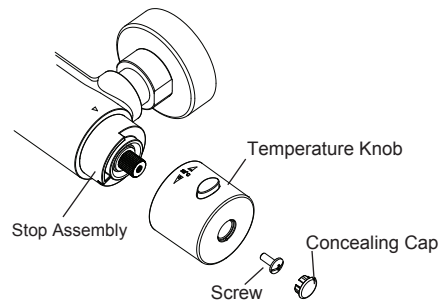

## INSTALLATION

### Thermostatic Bar Valve Installation

For the solid wall installation, the thermostatic bar valve can be supported by the pipework provided that it is securely fixed to the wall. For other wall types, some support fittings(not supplied) should be used to help installation.

1. Arrange the pipework, make sure that it is set at the correct distance apart (150±24mm) and solidly fixed.
2. Apply suitable thread sealant (not supplied) and attach the offset connectors to the pipework in the wall. The offset connectors must protrude between 35-40mm from the finished wall.

**Note !** Connections are **Hot-left, Cold-right**. This is very important as this product does not allow for reverse.

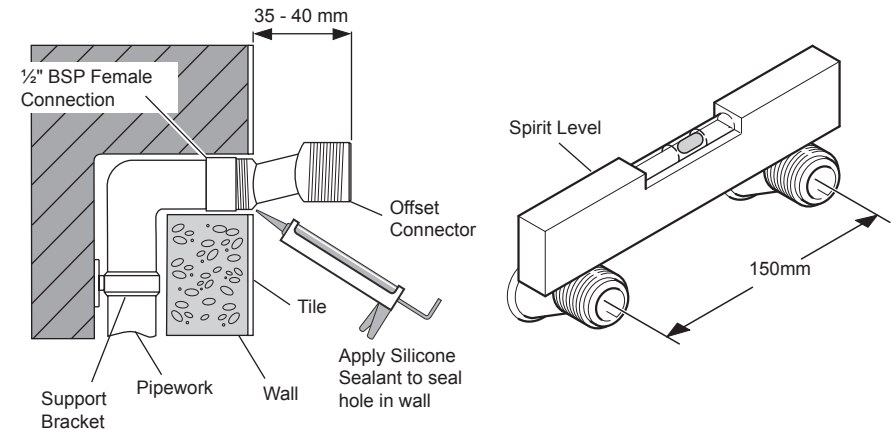

## INSTALLATION

3. Tighten the offset connectors using a spanner on the spanner flats. Make sure the connectors are level and set at correct distance apart, using the bar valve as a guide for spacing.
4. Place the concealing plates onto the offset connectors until they come into contact with the wall.
5. **Caution!** Make sure that the supply pipework is flushed before insatlling the bar valve. Assemble the bar valve with a sealing washer/filter in each inlet and attach offset connectors.
6. Tighten the connections using a suitable spanner.
7. Install the rigid riser assembly, go to section '**Rigid Riser Assembly Installation**'.

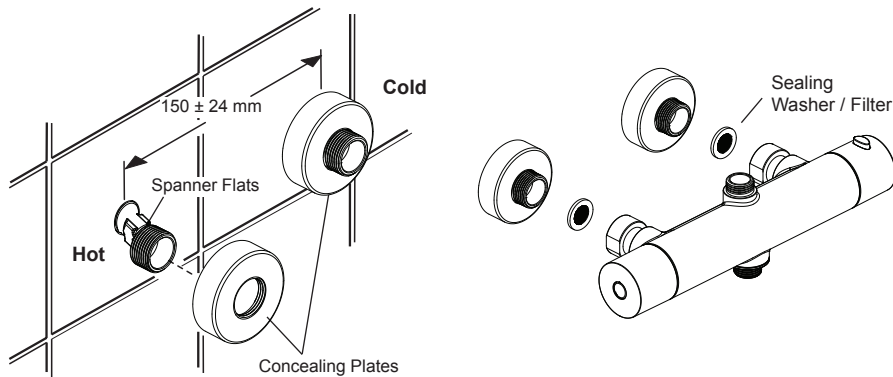

## INSTALLATION

### Rigid Riser Assembly Installation

1. Pressing the button, slide the showerhead holder over the rigid riser. In suitable position, release the button to secure the holder.
2. Insert the rigid riser into the rigid riser overhead pipe and then screw the grub screw to secure.
3. Locate the rigid riser rail into the valve outlet and the rigid riser overhead pipe into the securing bracket, make sure that they are pushed fully home.

**Important!** Align the rigid riser overhead pipe with the securing bracket using the grub screw. Then, using a spirit level make sure that the rigid riser rail is vertical and mark the position of the fixing holes for the securing bracket on the wall.

**Caution! Do not** cut the rigid riser rail.

4. For solid walls drill the fixing holes for the securing bracket with a 6 mm drill and insert the supplied wall plugs. For other types of wall structure alternative fixings may be required(not supplied).
5. Secure the securing bracket to the wall using the supplied screws.

