

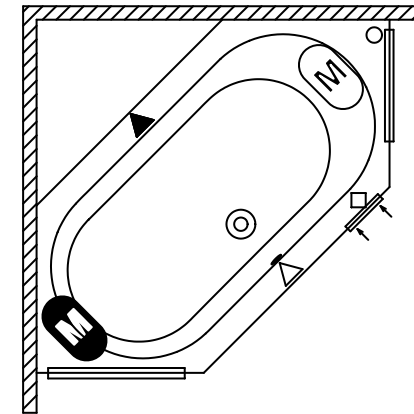







Standard type



-  Motor aero in double system (Hydro/Aero)
Motor aero v kombinovaném systému (Hydro/Aero)
-  Motor of single system (Hydro or Aero) or hydro motor in double system (Hydro/Aero)
Motor jednoduchého systému (Hydro nebo Aero) nebo motor hydro v kombinovaném systému (Hydro/Aero)
-  Electronic control / Elektronické ovládání
-  LCD electronic control / LCD elektronické ovládání
-  Cleanpool (combination of pneumatic control and cleanpool is not possible)
Čištění (kombinace mechanického ovládání a čištění není možná)
-  Pneumatic control (combination of pneumatic control and cleanpool is not possible)
Mechanické ovládání (kombinace mechanického ovládání a čištění není možná)
-  Inspection hatches / Servisní otvor
-  Inspection hatch for heater / Servisní otvor pro přehrev

Treatment:			
Material: Acryl			
Rev.	Change	noDev.	Date
A		C	
B		D	
		E	
		F	
		G	
		H	
Scale: 1:15 Format: A4 Unit: cm Sheet: 1 of 1 Tolerance: NEN-ISO 2768-1 class v			
Name: Kansas 190x90			
Linedrawing			
TILBURG HOLLAND		Drawn: LH	Date: 3-10-2006
Introduced by tech. change??/2006		Project no. 10.284	
Article nr.:		Draw no.:	
		BA970000	

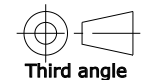

Third angle